

# artsound

## OPERATING MANUAL MX-60(M) MIXER ZONE AMPLIFIER



### Table of contents

<b>1. Safety precautions</b>	<b>2</b>
<b>2. General description</b>	<b>3</b>
<b>3. Features</b>	<b>3</b>
<b>4. Nomenclature and functions</b>	<b>4</b>
<b>4.1 Front panel</b>	<b>4</b>
<b>4.2 Rear panel</b>	<b>5</b>
<b>5. Specifications</b>	<b>7</b>
<b>6. Dimensional diagram</b>	<b>7</b>

Please follow the instructions in this manual to obtain the optimum results from this unit.  
We also recommend that you keep this manual handy for future reference

Check our website for any updates of this manual: [www.artsound.be](http://www.artsound.be)

## 1 Safety precautions.

- Be sure to read the instructions in this section carefully before use.
- Make sure to observe the instructions in this manual as the conventions of safety symbols and messages regarded as very important precautions are included.
- We also recommend you keep this instruction manual handy for future reference.

## Warnings and safety.

### SAFETY SYMBOL AND MESSAGE CONVENTIONS.

Safety symbols and messages described below are used in this manual to prevent bodily injury and property damage, which could result from mishandling. Before operating your product, read this manual first and understand the safety symbols and messages so you are thoroughly aware of the potential safety risk.



#### WARNING

**INDICATES A POTENTIALLY HAZARDOUS SITUATION WHICH, IF MISHANDLED, COULD RESULT IN DEATH OR SERIOUS PERSONAL INJURY.**



#### CAUTION

**INDICATES A POTENTIALLY HAZARDOUS SITUATION WHICH, IF MISHANDLED, COULD RESULT IN MODERATE OR MINOR PERSONAL INJURY, AND/OR PROPERTY DAMAGE.**

## Warning.

### WHEN INSTALLING THE UNIT.

- Do not expose the unit to rain or an environment where it may be splashed by water or other liquids, as doing so may result in fire or electric shock.
- Use the unit only with the voltage specified on the unit. Using a voltage higher than that which is specified may result in fire or electric shock.
- Do not cut, kink, otherwise damage nor modify the power supply cord. In addition, avoid using the power cord in close proximity to heaters, and never place heavy objects -- including the unit itself -- on the power cord, as doing so may result in fire or electric shock.
- Be sure to replace the unit's terminal cover after connection completion. Because high voltage is applied to the speaker terminals, never touch these terminals to avoid electric shock.
- Be sure to ground to the safety ground (earth) terminal to avoid electric shock. Never ground to a gas pipe as a catastrophic disaster may result.
- Avoid installing or mounting the unit in unstable locations, such as on a rickety table or a slanted surface. Doing so may result in the unit falling down, causing personal injury and/or property damage.

### WHEN THE UNIT IS IN USE.

- Should the following irregularity be found during use, immediately switch off the power, disconnect the power supply plug from the AC outlet and contact your nearest ArtSound dealer. Make no further attempt to operate the unit in this condition as this may cause fire or electric shock.
  - If you detect smoke or a strange smell coming from the unit.
  - If water or any metallic object gets into the unit
  - If the unit falls, or the unit case breaks
  - If the power supply cord is damaged (exposure of the core, disconnection, etc.)
  - If it is malfunctioning (no tone sounds.)
- To prevent a fire or electric shock, never open nor remove the unit case as there are high voltage components inside the unit. Refer all servicing to your nearest ArtSound dealer.
- Do not place cups, bowls, or other containers of liquid or metallic objects on top of the unit. If they accidentally spill into the unit, this may cause a fire or electric shock.
- Do not insert nor drop metallic objects or flammable materials in the ventilation slots of the unit's cover, as this may result in fire or electric shock.

## Caution.

### WHEN INSTALLING THE UNIT.

- Never plug in nor remove the power supply plug with wet hands, as doing so may cause electric shock.
- When unplugging the power supply cord, be sure to grasp the power supply plug; never pull on the cord itself. Operating the unit with a damaged power supply cord may cause a fire or electric shock.
- When moving the unit, be sure to remove its power supply cord from the wall outlet. Moving the unit with the power cord connected to the outlet may cause damage to the power cord, resulting in fire or electric shock. When removing the power cord, be sure to hold its plug to pull.
- Do not block the ventilation slots in the unit's cover. Doing so may cause heat to build up inside the unit and result in fire.
- Avoid installing the unit in humid or dusty locations, in locations exposed to the direct sunlight, near the heaters, or in locations generating sooty smoke or steam as doing otherwise may result in fire or electric shock.

### WHEN THE UNIT IS IN USE.

- Do not place heavy objects on the unit as this may cause it to fall or break which may result in personal injury and/or property damage. In addition, the object itself may fall off and cause injury and/or damage.
- Make sure that the volume control is set to minimum position before power is switched on.
- Loud noise produced at high volume when power is switched on can impair hearing.
- Do not operate the unit for an extended period of time with the sound distorting. This is an indication of a malfunction, which in turn can cause heat to generate and result in a fire.
- Contact your ArtSound dealer as to the cleaning. If dust is allowed to accumulate in the unit over a long period of time, a fire or damage to the unit may result.
- If dust accumulates on the power supply plug or in the wall AC outlet, a fire may result. Clean it periodically. In addition, insert the plug in the wall outlet securely.
- Switch off the power, and unplug the power supply plug from the AC outlet for safety purposes when cleaning or leaving the unit unused for 10 days or more. Doing otherwise may cause a fire or electric shock.

**AN ALL-POLE MAINS SWITCH WITH A CONTACT SEPARATION OF AT LEAST 3 MM IN EACH POLE SHALL BE INCORPORATED IN THE ELECTRICAL INSTALLATION OF THE BUILDING.**

Due to product upgrades, while some of the features and specification in the user manual does not match the actual functions, sorry for any inconvenience and thanks for your kind understanding!

## 2. General description.

The MX-60 (M) mixer-amplifier is an all-in-one solution for commercial and industrial applications in a compact size.

## 3. Features

- 3 mic inputs en 2 line-in with XLR, 6,3mm jack or RCA
- priority input + trigger contact (euroblock) with level and talkover control
- 3 levels of priority
- media source USB/SD, FM tuner, BT (ref. MX-60M)
- 60W power output @ 70V / 100V / 4 Ohm / 8 Ohm
- advanced protection system includes current limiting, over current and thermal protection
- two bands tone control (bass & treble)
- convection cooling – maintenance free
- compact size and lightweight

## 4. Nomenclature and functions.

### 4.1 FRONT PANEL

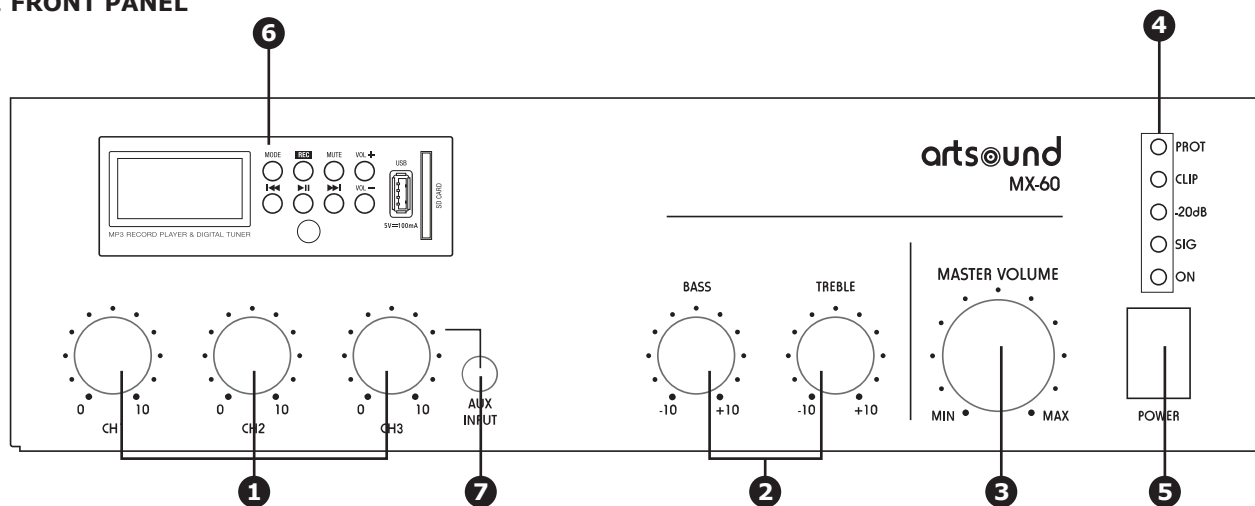

#### 1. CHANNEL VOLUME

Turn the buttons clockwise to increase volume, counter clockwise to decrease volume.

#### 2. BASS & TREBLE CONTROL

#### 3. MASTER VOLUME

#### 4. INDICATOR LEDS

Protection, output level, power.

#### 5. ON/OFF SWITCH

#### 6. BUILT IN SOURCE SD/USB, FM TUNER, BT (REF. MX-60M)

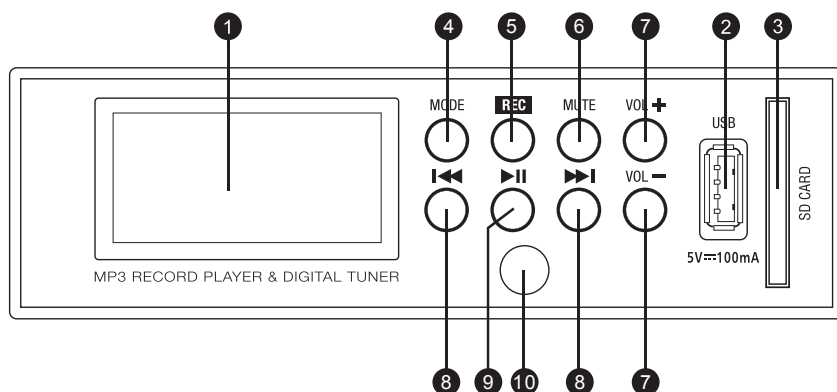

#### 1 Display

#### 2 USB input

#### 3 SD input

**4 MODE** Short press to select USB/SD/FM or Bluetooth. Press and hold to turn on and off of device power.

**5 REC** Short press to record current output audio to USB or SD card.

**6 MUTE** Short press to muting and releasing output audio.

**7 VOL+/VOL-** Short press to step up or down output volume. Press and hold to fast up or down output volume.

**8 PREVIOUS/NEXT** Short press to select previous or next FM frequency for tuner, to select previous or next track for USB,SD card. Press and hold to search previous or next FM frequency automatically for tuner, fast forward or rewind in current

track for USB,SD card.

**9 PLAY/PAUSE** Short press to move stored FM frequency for tuner, to toggle play and pause current track for USB,SD card. Press and hold to search and store audible FM frequency automatically for tuner, stop to play the current track for USB,SD card.

#### 10 IR COMMUNICATION

**Press the play button when Bluetooth as the source is selected to pair with the external device.**

#### 7. AUX INPUT – 3,5MM

## 4.2 REAR PANEL

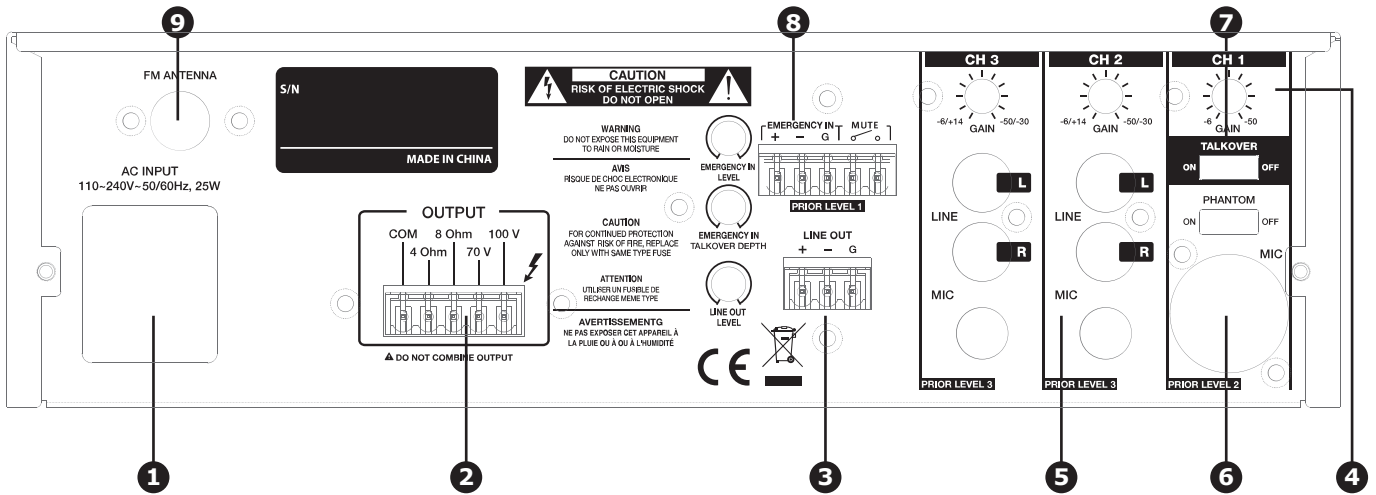

### 1. POWER CABLE INLET

### 2. SPEAKER CONNECTOR TERMINALS (COM, 4 Ohm, 8 Ohm, 70V, 100V)

#### ⚠ CAUTION

- Never use both the low impedant output (4Ω / 8Ω) and high impedant output (70V, 100V) terminals at the same time.
- Do not overload the speaker outputs. The total switched power of the speakers should be lower or equal to the output power of the amplifier.

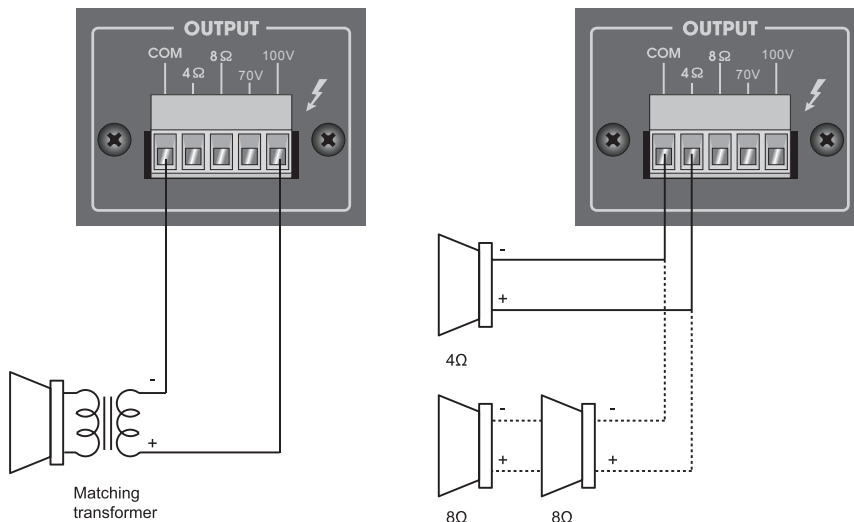

MX-60(M)	4Ω / 16V	8Ω / 22.8V	75Ω / 70V	154Ω / 100V
----------	----------	------------	-----------	-------------

### 3. LINE-OUT WITH LEVEL CONTROL (BUILT-IN SOURCE + LINE INPUT CH2/3)

### 4. GAIN CONTROLS FOR VARIABLE INPUT LEVEL

## 5. LINE-IN (RCA) OR MIC INPUT (6,3MM)

Below an illustration of the different connection possibilities

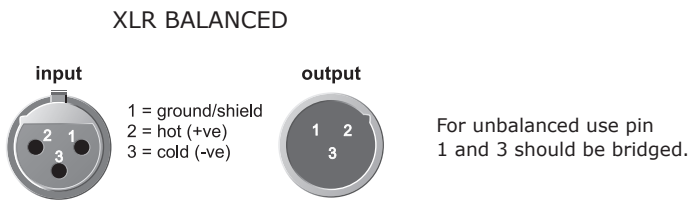
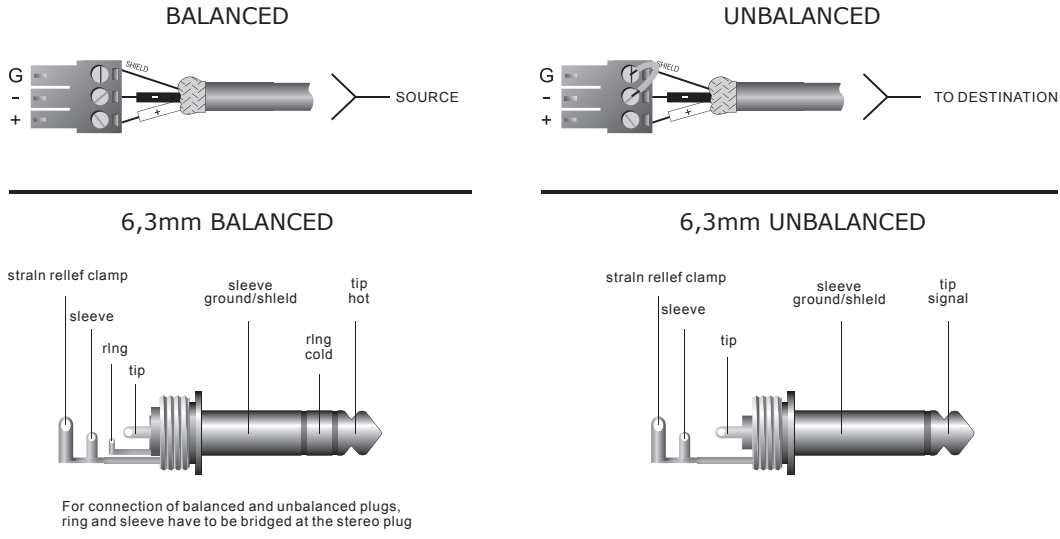

### GAIN CONTROLE

Each input can have its separate gain level.

### PRIORITY LEVELS

This amplifier has 3 levels of priority. Whenever a source with a higher priority is active all other sources will be muted.

**Priority input > Channel 1 > Channel 2/3/AUX**

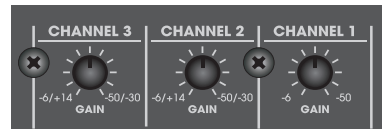

## 6. MIC (XLR) WITH PHANTOM SWITCH (ON/OFF)

## 7. TALKOVER SWITCH

## 8. PRIORITY INPUT WITH "MUTE ALL" CONTACT, LEVEL AND TALKOVER CONTROL

This input has absolute priority over all other sources either triggered by VOX or extra contact. The +-GND indication is used for the balanced line input. The extra contact next to it is optional.

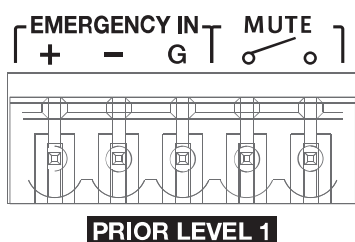

## 9. FM ANTENNA

## 5. Technical specifications

<b>100V MIXER-AMPLIFIER</b>	
Model	MX-60[M]
Rated output power (THD 0,5%)	1 x 60W
Loudspeaker terminals	4 Ohm / 8 Ohm / 70V / 100V
<b>Input Sensitivity for full output at maximum gain</b>	
Bal. microphone input	-50dB ± 3dB
Unbal. AUX input	-30dB ± 3dB
Priority input	-21dB ± 3dB
<b>Output voltage and impedance</b>	
4 Ohm	16V
8 Ohm	22,8V
70V	75 Ohm
100V	154 Ohm
Signal to noise ratio (rated power)	< 90 dB
Frequency range (1kHz)	80Hz~18kHz < 0.5% THD
Cooling	convection
Dimensions	270 x 76 x 230 mm
Weight	3,59 kg

## 6. Dimensional diagram.

UNIT : MM

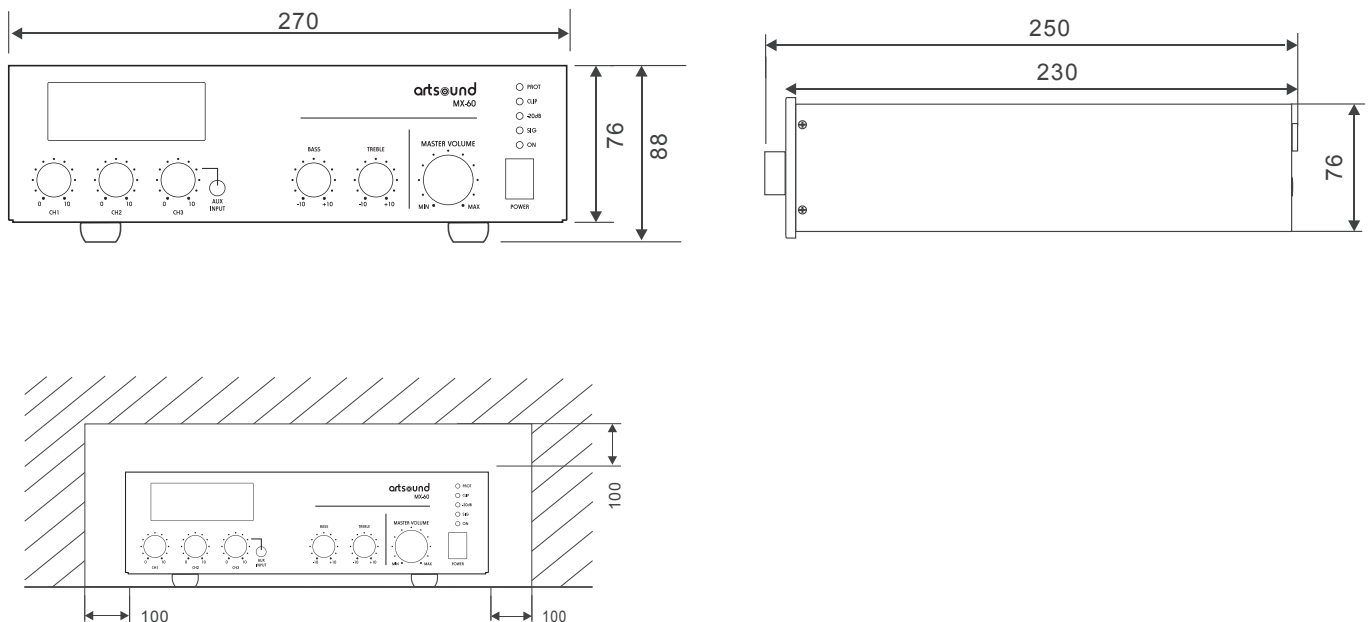

**Keep the unit's all sides over 10 cm away from objects that may obstruct air flow to prevent the unit's internal temperature rise.**

# artsound

smart solutions in audio

Designed in Europe - Made in China

---

House of Music nv  
Ronse, Belgium

☎ +32 9 380 81 80  
☎ +32 9 386 12 35  
✉ info@houseofmusic.be

🌐 www.artsound.be  
🐦 @Art\_Sound  
📘 ArtSound.Audio

Ontdek het volledige aanbod op [www.artsound.be](http://www.artsound.be)  
Découvrez la gamme complète sur [www.artsound.be](http://www.artsound.be)  
Discover the complete range at [www.artsound.be](http://www.artsound.be)

**artsound**  
smart solutions in audio