



LU9235 / LX9215
Digital Projector
User Manual



Copyright and disclaimer

Copyright

Copyright 2015 BenQ Corporation. All rights reserved. No part of this publication may be reproduced, transmitted, transcribed, stored in a retrieval system or translated into any language or computer language, in any form or by any means, electronic, mechanical, magnetic, optical, chemical, manual or otherwise, without the prior written permission of BenQ Corporation. All other logos, products, or company names mentioned in this manual may be the registered trademarks or copyrights of their respective companies, and are used for informational purposes only.

Disclaimer

BenQ Corporation makes no representations or warranties, either expressed or implied, with respect to the contents hereof and specifically disclaims any warranties, merchantability or fitness for any particular purpose. Further, BenQ Corporation reserves the right to revise this publication and to make changes from time to time in the contents hereof without obligation of BenQ Corporation to notify any person of such revision or changes.

This user manual aims to provide the most updated and accurate information to customers, and thus all contents may be modified from time to time without prior notice. Please visit <http://www.benq.com> for the latest version of this manual.

Statement regarding hyperlinks and third-party websites

BenQ is not responsible for the content of the websites or of similar resources, which are maintained and controlled by third parties, that may be linked from this product. Providing links to those websites or to similar resources does not mean that BenQ makes any warranty or representation to their content by expression or by implication.

Any third party content or service preinstalled in this product is provided "as is". BenQ does not, by expression or by implication, make any warrant to the content or to the services provided by third parties. BenQ does not warrant or guarantee that the content or services provided by third parties are accurate, effective, most up-to-date, legal, or complete. Under no circumstances shall BenQ be liable for the content or services provided by third parties including their negligence. Services provided by third parties may be terminated temporarily or permanently. BenQ does not warrant or guarantee that the any content or services provided by third parties are in good condition at any time, and is not liable for the termination of the said content and services. In addition, BenQ is not involved in any transactions you conduct in the websites or similar resources maintained by third parties.

You should contact the content or service providers for any questions, concerns, or disputes.

Table of Contents

Copyright and disclaimer	2
Copyright.....	2
Disclaimer.....	2
Statement regarding hyperlinks and third-party websites	2
Important safety instructions.....	6
General safety instruction	6
Notice on laser.....	7
Laser class.....	7
Laser parameters	7
Label instruction	8
Laser light instruction	9
Prepare for installation	10
Caution for installation.....	10
Cooling notice	11
Package contents	13
Standard packing items	13
Lens information.....	13
Introduction.....	14
Projector exterior view.....	14
Front and upper side view	14
Rear and upper side view.....	14
Controls and functions.....	15
Control panel.....	15
Control terminal	16
Remote control	17
Installation	21
Installing removing the optional lens	21
Installing the new lens.....	21
Removing the existing lens from the projector	22
Evaluate for distance by image size.....	23
Obtaining a preferred projected image size	23
Projection dimensions.....	23
Lens dimension.....	25
Adjusting by Lens shift	26
Adjusting the vertical image position	26
Adjusting the horizontal image position.....	26
Lens shift range diagram.....	27
Adjusting the Zoom/Focus	28
Connection	29
Before connecting.....	29
Connecting with AV equipment.....	31
Connecting with computer	31
Connecting with HDBaseT transmitter	32

Connecting with LAN.....	32
--------------------------	----

Operations..... 33

Switch on/off the projector.....	33
Connecting the power cord.....	33
Power indicator.....	33
Switch on the projector.....	34
Switch off the projector.....	40

Using the menu..... 41

Main menu.....	41
Display menu.....	42
Corner Fit menu.....	44
3D menu.....	44
Picture menu.....	45
Color Temperature Fine Tuning menu.....	47
3D Color Management menu.....	48
Source menu.....	49
System setup : Basic menu.....	50
Menu Settings menu.....	51
Operation Settings menu.....	51
System setup : Advanced menu.....	52
Audio Settings menu.....	53
Light Source Settings menu.....	54
Security Settings menu.....	54
Closed Caption menu.....	55
Standby Settings menu.....	55
Network Settings menu.....	56
Information menu.....	57
Menu structure.....	58

Maintenance..... 61

Before maintaining the projector.....	61
Care of the projector.....	61
Clean the lens front surface.....	61
Clean the projector case.....	61
Filter maintenance.....	62
Cleaning the filter.....	62
Replacing the side filter.....	63
Replacing the front filter.....	64
LED indicator.....	65
System message.....	65
Light source error message.....	65
Filter message.....	65
Thermal error message.....	66

Troubleshooting	67
Troubleshooting.....	67
The projector does not turn on.....	67
No picture.....	67
Blurred image.....	67
Remote control does not work.....	67
The password is incorrect.....	67
Specifications.....	68
Specifications	68
Dimensions	69
Attaching for ceiling mount	69
Appendix.....	70
Timing table	70
Supported timing for PC & PC 2 input.....	70
Support timing for Component - YPbPr input	71
Support timing for Video input.....	72
Support timing for HDMI & DVI-D (HDCP) input.....	72
Supporting timing for HDMI Video input.....	74
RS232 command control	75
PJLink	79
PJLink protocol.....	79
Control commands.....	79

Important safety instructions

Your projector is designed and tested to meet the latest standards for safety of information technology equipment. However, to ensure safe use of this product, it is important that you follow the instructions mentioned in this manual and marked on the product.

General safety instruction

1. Do not look straight at the projector lens during operation. The intense light beam may damage your eyes.
2. Always open the lens shutter or remove the lens cap when the projector light source is on.
3. In some countries, the line voltage is NOT stable. This projector is designed to operate safely within a mains voltage between 100 to 240 volts AC, but could fail if power cuts or surges of ± 10 volts occur. In areas where the mains voltage may fluctuate or cut out, it is recommended that you connect your projector through a power stabilizer, surge protector or uninterruptible power supply (UPS).
4. Do not block the projection lens with any objects when the projector is under operation as this could cause the objects to become heated and deformed or even cause a fire. To temporarily turn off the light source, press **BLANK** on the remote control.
5. Do not place this product on an unstable cart, stand, or table. The product may fall, sustaining serious damage.
6. Do not attempt to disassemble this projector. There are dangerous high voltages inside which may cause death if you should come into contact with live parts.
Under no circumstances should you ever undo or remove any other covers. Refer servicing only to suitably qualified professional service personnel.
7. Do not place this projector in any of the following environments.
 - Space that is poorly ventilated or confined. Allow at least 50 cm clearance from walls and free flow of air around the projector.
 - Locations where temperatures may become excessively high, such as the inside of a car with all windows rolled up.
 - Locations where excessive humidity, dust, or cigarette smoke may contaminate optical components, shortening the projector's life span and darkening the image.
 - Locations near fire alarms
 - Locations with an ambient temperature above 40°C / 104°F
 - Locations where the altitudes are higher than 3000 m (10000 feet).
8. Do not block the ventilation holes.
 - Do not place this projector on a blanket, bedding or any other soft surface.
 - Do not cover this projector with a cloth or any other item.
 - Do not place inflammables near the projector.

If the ventilation holes are seriously obstructed, overheating inside the projector may result in a fire.

9. Do not step on the projector or place any objects upon it. Besides probable physical damage to the projector, doing so may result in accidents and possible injury.
10. Do not place liquids near or on the projector. Liquids spilled into the projector may cause it to fail. If the projector does become wet, disconnect it from the power supply's wall socket and call BenQ to have the projector serviced.

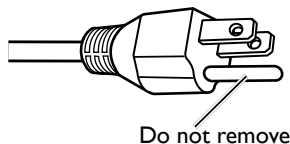

This equipment has a three-pin grounding-type power plug. Do not remove the grounding pin. As a safety feature, this plug will only fit a grounding-type power outlet. If you are unable to fit the plug into the outlet, contact an electrician.

Notice on laser



This symbol indicates that there is a potential hazard of eye exposure to laser radiation unless the instructions are closely followed.

Laser class



This Laser Product is designated as Class 3R during all procedures of operation. **LASER LIGHT - AVOID DIRECT EYE EXPOSURE.**

Do not point laser or allow laser light to be directed or reflected toward other people or reflective objects.



Direct or scattered light can be hazardous to eyes and skin.

There is a potential hazard of eye exposure to laser radiation if the included instructions are not followed.

Caution – use of controls or adjustments or performance of procedures other than those specified herein may result in hazardous radiation exposure.

Laser parameters

Wavelength	450nm - 460nm (Blue)
Mode of operation	Pulsed, due to frame rate
Pulse width	1.34ms
Pulse repetition rate	120Hz
Maximum laser energy	0.698mj
Total internal power	>100w
Apparent source size	>10mm, at lens stop
Divergence	>100 mili Radian

Label instruction

Below drawing show the label's location.

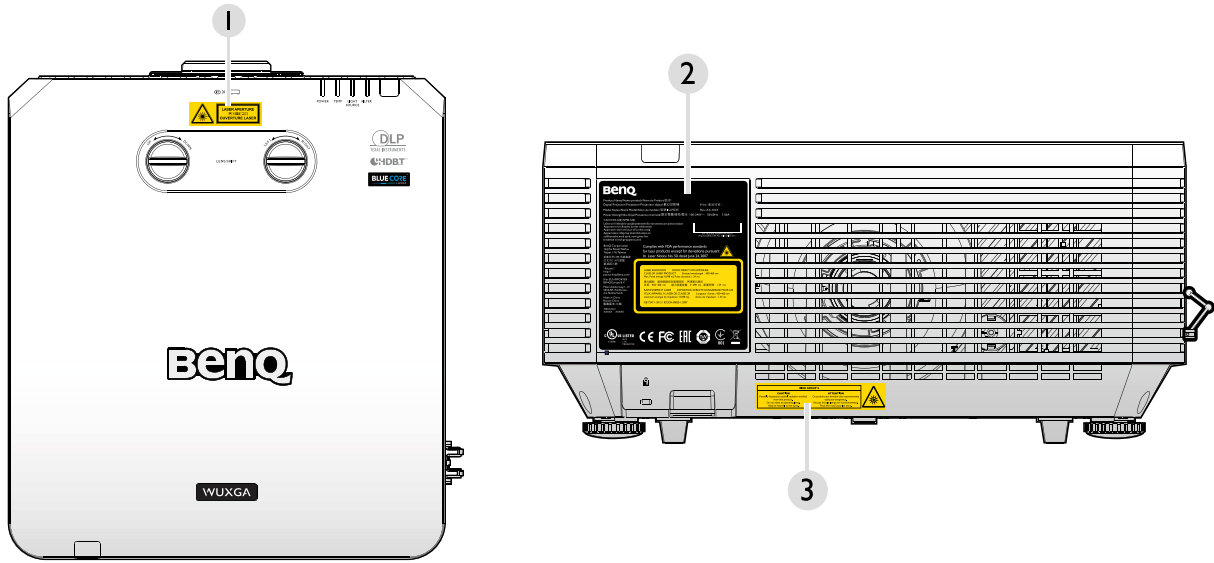

1. Laser warning label



2. Spec label



3. Explanatory Label

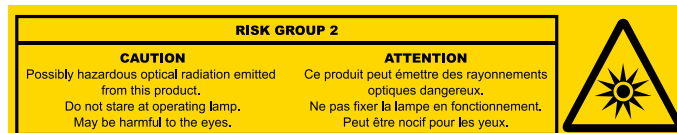

Laser light instruction

Below drawing is the laser aperture location. Be careful not to let the eye see the light directly.



Interlock switches

This machine has 2 (Top cover x 1, Lens x 1) Interlock switches to protect the laser light Leakage.

1. Will power-off the system individually when the top cover is removed.
2. Will power-off the system individually when the lens is removed or not install correctly.



Prepare for installation

Caution for installation

1. If the projector and lens were purchased separately, remove the anti-dust cap before use and store it for future use. When transporting the projector, move the lens to the home position, remove the lens, and attach the anti-dust cap.

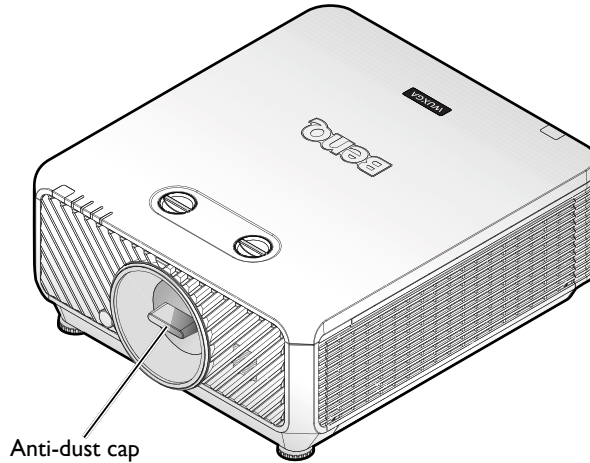

2. When the projector is not in use, attach the lens cover supplied with the projector or the projection lens.



Focus adjustment

The high clarity projection lens is thermally affected by the light from the bulb; thus, the focus is unstable for a short period immediately after the power is turned on. Please wait at least 15 minutes of continuous projection before adjusting the focus.

Cooling notice

Allow at least 500 mm (19.7 in) for clearance around the exhaust vent. Make sure no objects block air input within 300 mm (11.8 in).

Keep the outlet at least 1 m away from the inlets of other projectors.

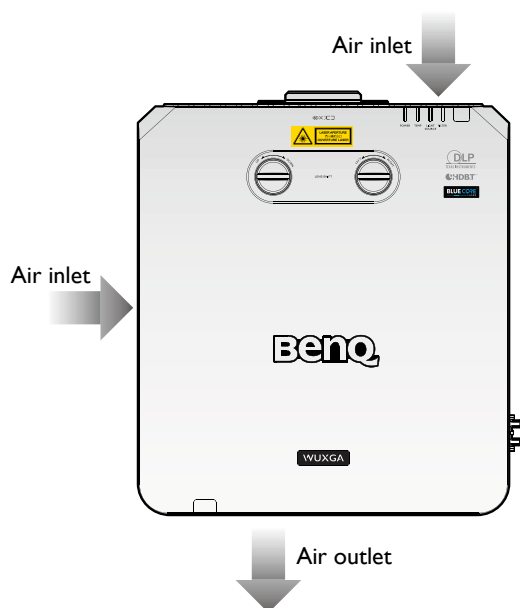

- The projector can be installed at any angle.

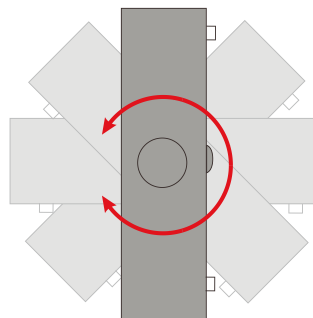
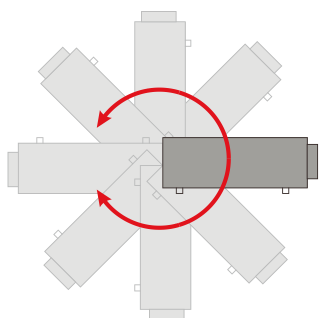

- Allow at least 50 cm of clearance around the exhaust vent.

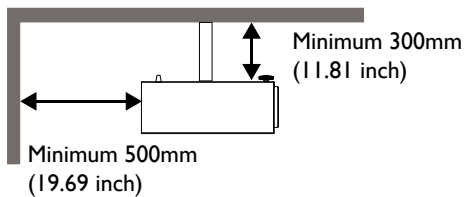
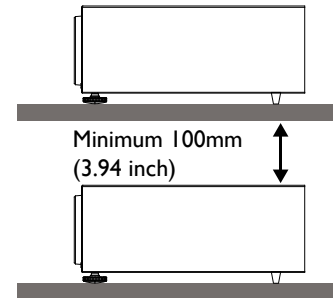
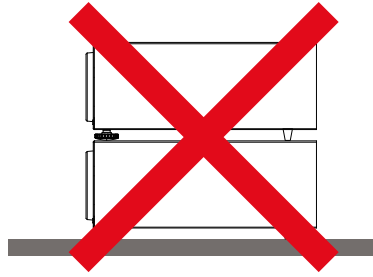
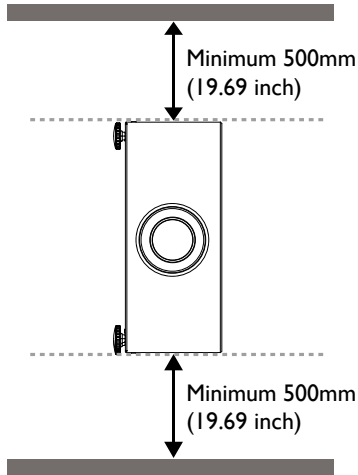
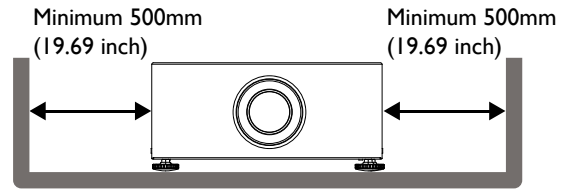
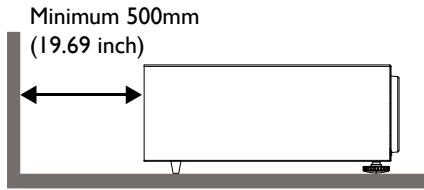

- Ensure that the air intake vents do not recycle hot air from the exhaust vent.
- When operating in an enclosed space, make sure that the surrounding air temperature does not exceed the projector's operating temperature and that the air intake and exhaust vents are unobstructed.
- All enclosures should pass a certified thermal evaluation to ensure that the projector does not recycle exhaust air. Recycling exhaust air may cause the projector to shutdown even if the ambient temperature is within the acceptable operating temperature range.

Package contents

Standard packing items

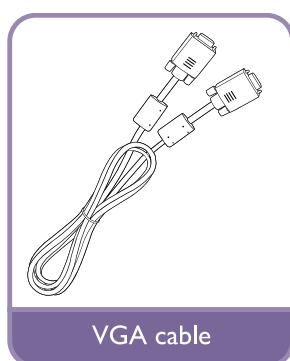
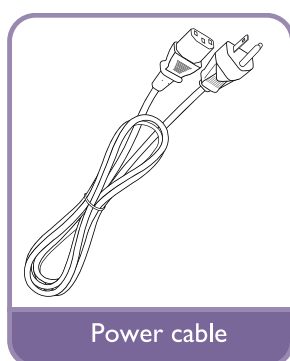
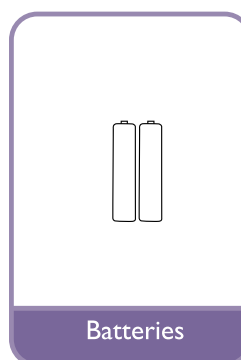

Lens information

Model	Lens Type	Part Number	Throw Ratio	Lens Shift
LS2ST3	Wide fix	5J.JDH37.002	XGA: 0.81 WUXGA: 0.778	Vertical: -15%-55% (WUXGA), -10%-50% (XGA) Horizontal: -5%-5%
LS2ST1	Wide zoom	5J.JDH37.011	XGA: 1.14-1.347 WUXGA: 1.1-1.3	Vertical: -15%-55% (WUXGA), -10%-50% (XGA) Horizontal: -5%-5%
LS2SD2	Standard	5J.JEN37.001	XGA: 1.6-2 WUXGA: 1.54-1.93	Vertical: -15%-55% (WUXGA), -10%-50% (XGA) Horizontal: -5%-5%
LS2LT1	Semi long	5J.JDH37.032	XGA: 2-3 WUXGA: 1.93-2.9	Vertical: -15%-55% (WUXGA), -10%-50% (XGA) Horizontal: -5%-5%
LS2LT2	Long zoom	5J.JDH37.041	XGA: 3.11-5.18 WUXGA: 3-5	Vertical: -15%-55% (WUXGA), -10%-50% (XGA) Horizontal: -5%-5%

Introduction

Projector exterior view

Front and upper side view

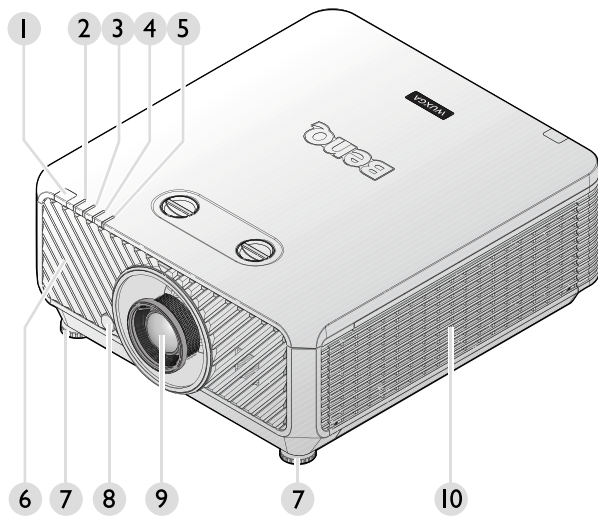

1. Front IR remote sensor
2. FILTER indicator light
3. LIGHT SOURCE indicator light
4. TEMPerature indicator light
5. POWER indicator light
6. Front vent (cool air intake)
7. Front adjuster feet
8. LENS RELEASE button
9. Projection lens
10. Side vent (cool air intake)

Rear and upper side view

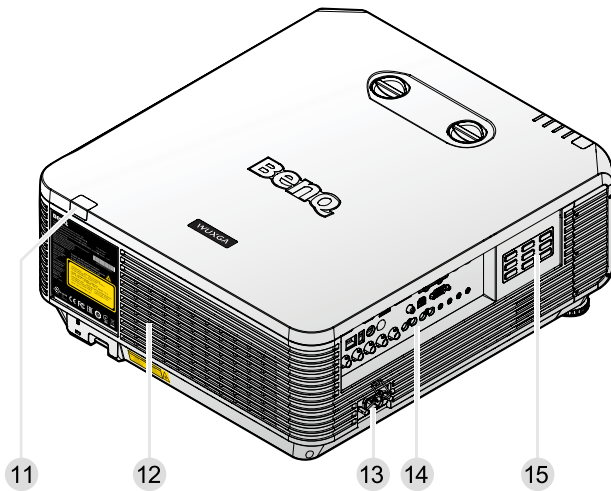

11. Rear IR remote sensor
12. Vent (cool air outtake)
13. AC power cord inlet
14. Control terminals
15. Control panel

Controls and functions

Control panel

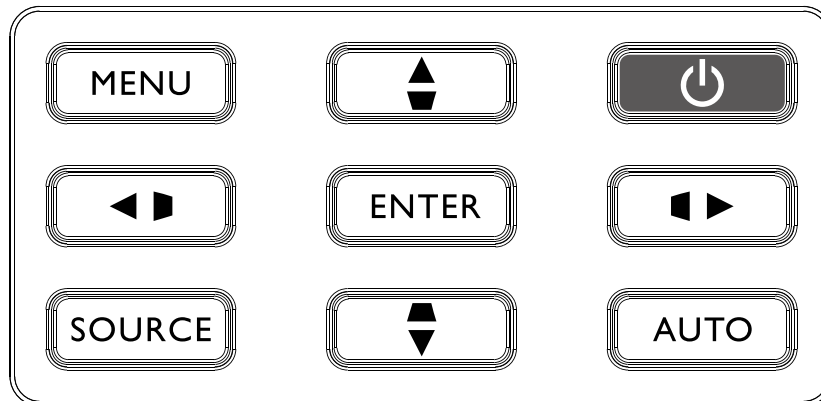

- **MENU**
Turns on the On-Screen Display (OSD) menu. Goes back to previous OSD menu, exits and saves menu settings. See ["Using the menu" on page 41](#) for details.
- **Keystone/Arrow keys (▶/◀ Left)**
Manually corrects distorted images resulting from an angled projection.
- **SOURCE**
Displays the source selection bar.
- **ENTER**
Selects an available picture setup mode.
Enacts the selected On-Screen Display (OSD) menu item. See ["Using the menu" on page 41](#) for details.
- **Keystone/Arrow keys (▲/▼ Down)**
Manually corrects distorted images resulting from an angled projection.
- **AUTO**
Automatically determines the best picture timings for the displayed image. See ["Auto adjusting the image" on page 39](#) for details.
- **Keystone/Arrow keys (◀/▶ Right)**
Manually corrects distorted images resulting from an angled projection.
- **Power**
Toggles the projector between standby mode and on. See ["Switch on the projector" on page 34](#) and ["Switch off the projector" on page 40](#) for details.
- **Keystone/Arrow keys (▼/▲ Up)**
When the On-Screen Display (OSD) menu is activated, the ▲, ▼, ◀, and ▶ keys are used as directional arrows to select the desired menu items and to make adjustments. See ["Using the menu" on page 41](#) for details.

Control terminal

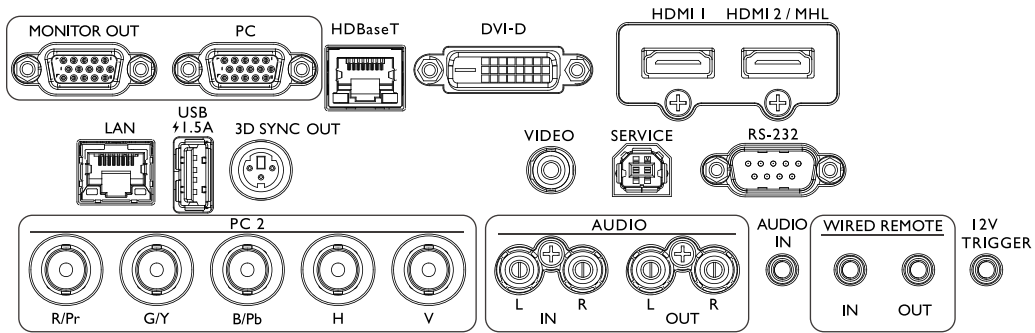

- **MONITOR OUT**
Connection to other display equipment for concurrent playback display.
- **PC**
15-pin VGA port for connection to RGB, component HD source, or PC.
- **HDBaseT**
For connection to RJ45 Cat5/Cat6 cable to input uncompressed high-definition video (HD).
- **DVI-D**
Connection to DVI source.
- **HDMI I**
Connection to HDMI source.
- **HDMI 2/MHL**
Connection to HDMI or MHL source.
- **LAN**
For connection to RJ45 Cat5/Cat6 Ethernet cable to control the projector through a network.
- **USB 1.5A**
Support 5V/1.5A output.
- **3D SYNC OUT**
Connection to 3D IR sync signal transmitter.
- **VIDEO**
Connection to a video source.
- **SERVICE**
Maintenance exclusive port for authorized maintenance personnel only.
- **RS-232**
Standard 9-pin D-sub interface for connection to PC control system and projector maintenance.
- **PC 2 (R/Pr, G/Y, B/Pb, H, V)**
Connection to RGB or YPbPr/YCbCr output signal with BNC type input terminal.
- **AUDIO IN (L/R)**
Connection to an audio input source via an audio or audio L/R cable.
- **AUDIO OUT (L/R)**
Connection to a speaker or headset.
- **AUDIO IN**
Connection to an audio input source via an audio cable.
- **WIRED REMOTE IN**
Connection to remote control for wire remote control.

Caution:

Make sure the port is valid before inserting a wired remote controller. The remote controller may be damaged in case of an invalid port, e.g. a wired remote controller is connected to trigger output.

- **WIRED REMOTE OUT**
Connection to another projector.
- **12V TRIGGER**
3.5mm mini earphone jack, employs 200mA display relay to provide 12(+/-1.5)V output and short circuit protection.

Remote control

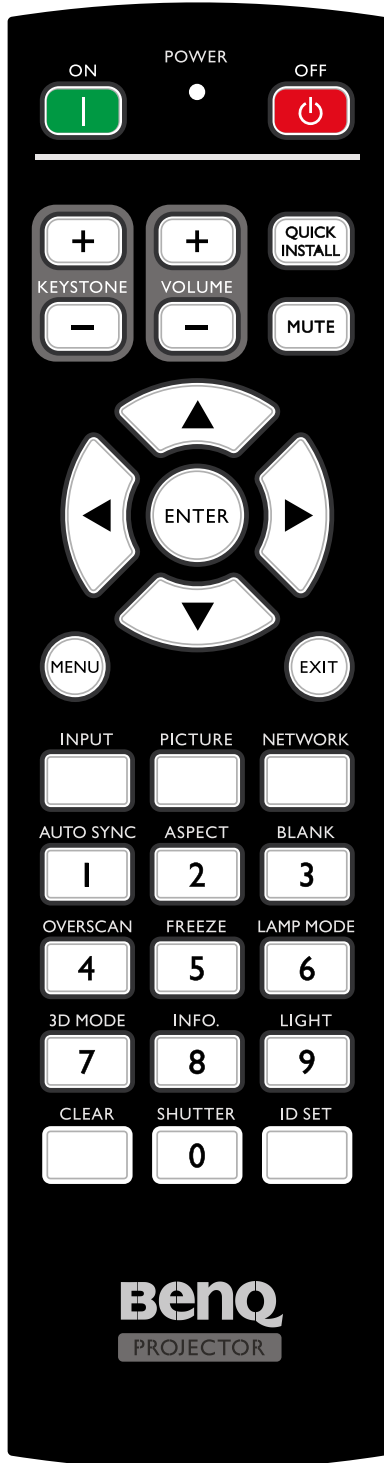

- **ON / OFF**
Toggles the projector between standby mode and on.
- **KEYSTONE+/KEYSTONE-**
Manually corrects distorted images resulting from an angled projection.
- **VOLUME +/VOLUME -**
Increases/decreases the projector volume.
- **QUICK INSTALL**
Displays the **Quick Install** OSD menu.
- **MUTE**
Toggles projector audio between on and off.
- **Arrow keys (▲ Up, ▼ Down, ◀ Left, ▶ Right)**
When the On-Screen Display (OSD) menu is activated, the arrow keys are used as directional arrows to select the desired menu items and to make adjustments. See ["Using the menu" on page 41](#) for details.
- **ENTER**
Selects an available picture setup mode. Activates the selected On-Screen Display (OSD) menu item.
- **MENU**
Turns on the On-Screen Display (OSD) menu. Goes back to previous OSD menu, exits and saves menu settings.
- **EXIT**
Goes back to previous OSD menu, exits and saves menu settings.
- **INPUT**
Selects an input source for display.
- **PCITURE**
Press to display **Picture** menu.
- **NETWORK**
Selects Network Display as the input signal source.
- **AUTO SYNC**
Automatically determines the best picture timings for the displayed image.
- **ASPECT**
Selects the display aspect ratio.
- **BLANK**
Used to hide the screen picture.

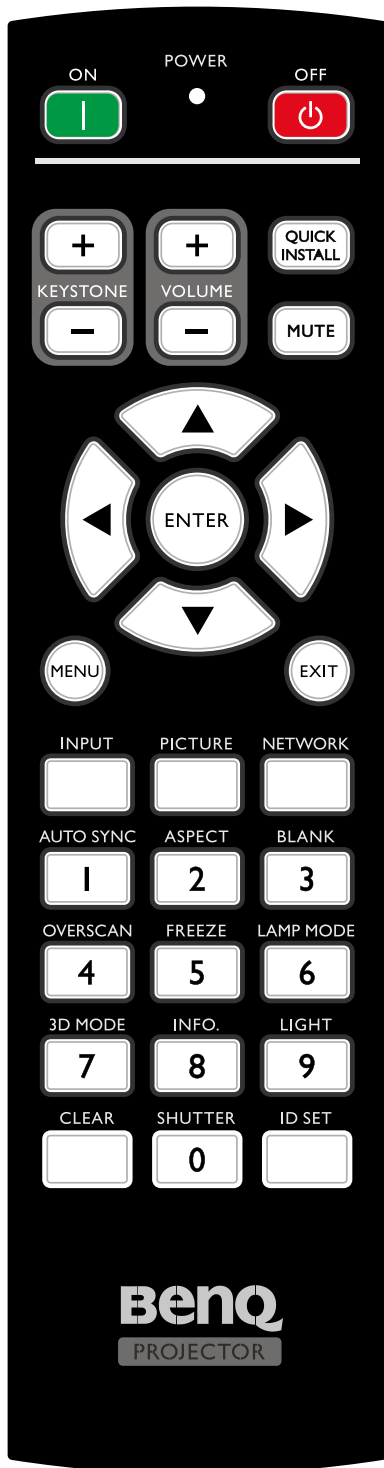

- **OVERSCAN**
Press to select overscan mode.
 - **FREEZE**
Freezes the projected image.
 - **LAMP MODE**
Press to display OSD menu to select desired light source mode.
 - **3D MODE**
Press to display 3D setup menu.
 - **INFO.**
Press to display INFORMATION menu.
 - **LIGHT**
Press to open backlight of remote controller.
 - **CLEAR**
Clear remote ID SET assigned to all projectors.
Press **CLEAR** and **ID SET** for five seconds. The LED blinks three times then the ID setting is cleared.
 - **SHUTTER**
The function is not available on this projector.
 - **ID SET**
 - Remote control ID SET (set the particular remote code)
Press to set remote ID.
Press **ID SET** for three seconds. The **POWER** indicator on the remote control blinks, then press 01~99 to designate an ID.
- Note:**
The remote control number (Remote control ID) must match the Projector ID Setting number for accurate control.
- Clear Remote ID SET (set remote code to all)
Press **CLEAR** and **ID SET** for five seconds. The **POWER** indicator on the remote control blinks a single instance to reset remote code to all, can control projector no matter projector id setting.
 - **Numeric buttons**
Enters numbers in network settings.
Numeric buttons 1, 2, 3, 4 cannot be pressed when asked to enter password.
 - **WIRE REMOTE jack**
Connect to projector for wire remote control.

Connect with projector

When you use a system with multiple projectors, use commercially available M3 stereo mini jack cables to connect the other projectors via the WIRED REMOTE IN/WIRED REMOTE OUT terminals.

The remote control is effective even in places where obstacles stand in the light path or where devices are susceptible to outside light.

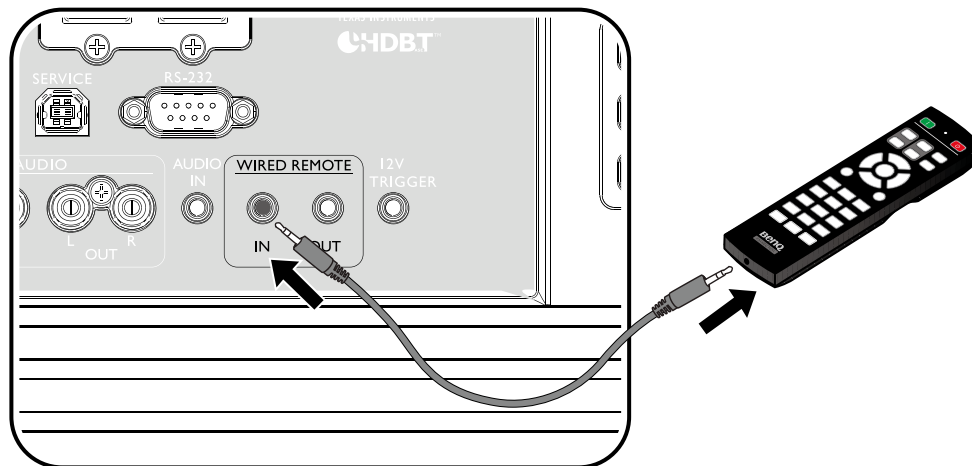

Note:

Use two core shielded cables no longer than 15 m (49.2 ft). The remote control may not operate when the length of the cable exceeds 15 m (49.2 ft) or when it is not properly shielded.

Remote control effective range

Infra-Red (IR) remote control sensor is located on the front and rear of the projector. The remote control must be held at an angle within 30 degrees perpendicular to the projector's IR remote control sensor to function correctly. The distance between the remote control and the sensor should not exceed 8 meters (~ 26 feet).

Make sure that there are no obstacles between the remote control and the IR sensor on the projector that might obstruct the infra-red beam.

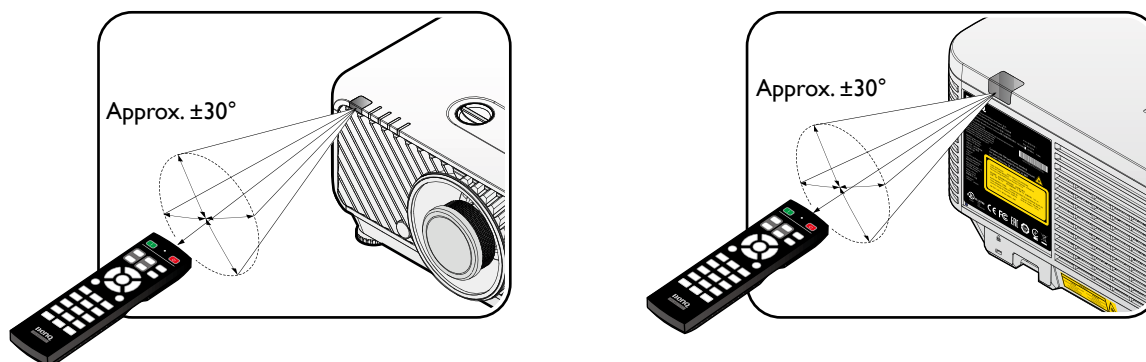

Replacing the remote control battery

1. To open the battery cover, turn the remote control over to view its back, push on the finger grip on the cover and slide it up in the direction of the arrow as illustrated. The cover will slide off.
2. Remove any existing batteries (if necessary) and install two AA batteries observing the battery polarities as indicated in the base of the battery compartment. Positive (+) goes to positive and negative (-) goes to negative.
3. Refit the cover by aligning it with the base and sliding it back down into position. Stop when it clicks into place.

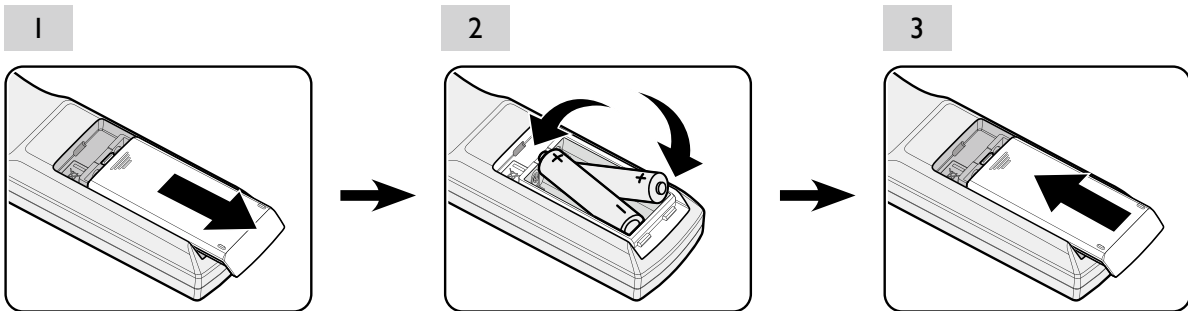

Caution:

- Avoid excessive heat and humidity.
- There may be battery damage if the battery is incorrectly replaced.
- Replace only with the same or equivalent type recommended by the battery manufacturer.
- Dispose of the used battery according to the battery manufacturer's instructions.
- Never throw a battery into a fire. There may be danger of an explosion.
- If the battery is dead or if you will not be using the remote control for a long time, remove the battery to prevent damage to the remote control from possible battery leakage.

Installation

Installing removing the optional lens

Caution:

- Do not shake or place excessive pressure on the projector or the lens components as the projector and lens components contain precision parts.
- Before removing or installing the lens, be sure to turn off the projector, wait until the cooling fans stop, and turn off the main power switch.
- Do not touch the lens surface when removing or installing the lens.
- Keep fingerprints, dust or oil off the lens surface. Do not scratch the lens surface.
- Work on a level surface with a soft cloth under it to avoid scratching.
- If you remove and store the lens, attach the lens cap to the projector to keep off dust and dirt.

Installing the new lens

Remove both end caps from the lens.

Note:

Removal of the plastic body cap before inserting a lens for the first time.

1. Align the flange and correctly position at the 11 o'clock position as shown in the picture.

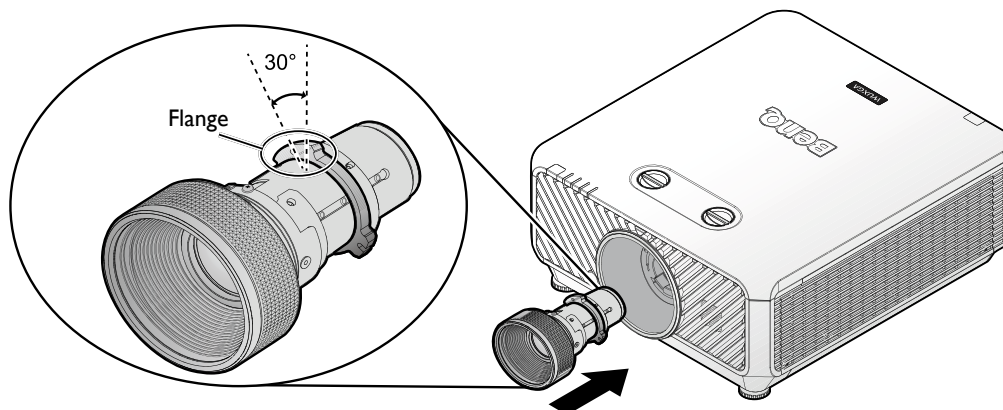

Note:

Flange must be positioned at the 11 o'clock position, direction as shown in the picture.

2. Rotate the lens clockwise until you feel it click into place.



Removing the existing lens from the projector

1. Push the LENSE RELEASE button to the unlock position.

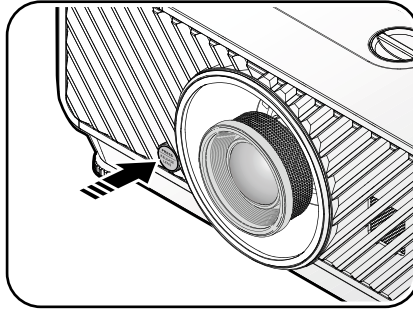

2. Grasp the lens.
3. Rotate the lens counterclockwise. The existing lens will be disengaged.



4. Pull out the existing lens slowly.

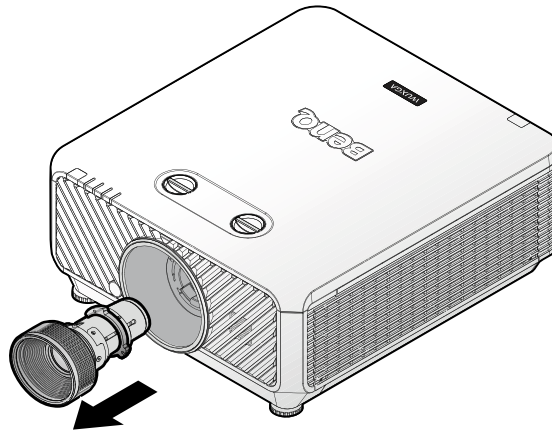

Evaluate for distance by image size

Obtaining a preferred projected image size

The distance from the projector lens to the screen, the zoom setting (if available), and the video format each factors in the projected image size.

Projection dimensions

Refer to "Dimensions" on page 69 for the center of lens dimensions of this projector before calculating the appropriate position.

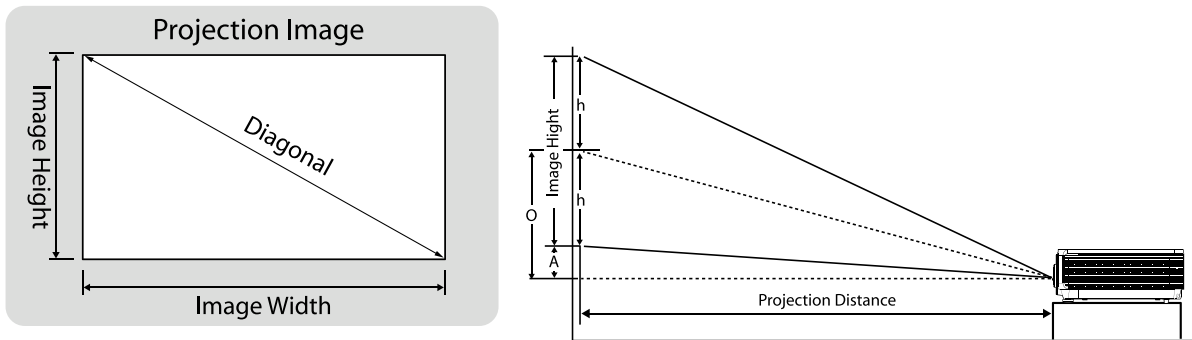

LX9215

The screen aspect ratio is 4:3 and the projected picture is 4:3.

Lens										Wide Zoom (LS2ST1)				Standard (LS2SD2)			
Throw ratio										1.14~1.347				1.6~2			
Diagonal		Image Width		Image Height		Offset (A)		O		Distance				Distance			
						Wide/Tele		Wide/Tele		Wide		Tele		Wide		Tele	
(Inch)	(m)	(Inch)	(m)	(Inch)	(m)	(Inch)	(m)	(Inch)	(m)	(Inch)	(m)	(Inch)	(m)	(Inch)	(m)	(Inch)	(m)
80	2.03	64	1.63	48	1.22	0.0	0.000	24.0	0.610	73	1.85	86	2.19	102	2.60	128	3.25
100	2.54	80	2.03	60	1.52	0.0	0.000	30.0	0.762	91	2.32	108	2.74	128	3.25	160	4.06
120	3.05	96	2.44	72	1.83	0.0	0.000	36.0	0.914	109	2.78	129	3.28	154	3.90	192	4.88
150	3.81	120	3.05	90	2.29	0.0	0.000	45.0	1.143	137	3.47	162	4.11	192	4.88	240	6.10
200	5.08	160	4.06	120	3.05	0.0	0.000	60.0	1.524	182	4.63	216	5.47	256	6.50	320	8.13
300	7.62	240	6.10	180	4.57	0.0	0.000	90.0	2.286	274	6.95	323	8.21	-	-	-	-
400	10.16	320	8.13	240	6.10	0.0	0.000	120.0	3.048	-	-	-	-	-	-	-	-

Lens										Semi Long (LS2LT1)				Long Zoom (LS2LT2)				Wide Fix (LS2ST3)	
Throw ratio										2~3				3.11~5.18				0.81	
Diagonal		Image Width		Image Height		Offset (A)		O		Distance				Distance				Distance	
						Wide/Tele		Wide/Tele		Wide		Tele		Wide		Tele		NA	
(Inch)	(m)	(Inch)	(m)	(Inch)	(m)	(Inch)	(m)	(Inch)	(m)	(Inch)	(m)	(Inch)	(m)	(Inch)	(m)	(Inch)	(m)	(Inch)	(m)
80	2.03	64	1.63	48	1.22	0.0	0.000	24.0	0.610	128	3.25	192	4.88	199	5.06	332	8.42	52	1.32
100	2.54	80	2.03	60	1.52	0.0	0.000	30.0	0.762	160	4.06	240	6.10	249	6.32	414	10.53	65	1.65
120	3.05	96	2.44	72	1.83	0.0	0.000	36.0	0.914	192	4.88	288	7.32	299	7.58	497	12.63	78	1.98
150	3.81	120	3.05	90	2.29	0.0	0.000	45.0	1.143	240	6.10	360	9.14	373	9.48	622	15.79	97	2.47
200	5.08	160	4.06	120	3.05	0.0	0.000	60.0	1.524	320	8.13	480	12.19	498	12.64	829	21.05	130	3.29
300	7.62	240	6.10	180	4.57	0.0	0.000	90.0	2.286	480	12.19	720	18.29	746	18.96	1243	31.58	194	4.94
400	10.16	320	8.13	240	6.10	0.0	0.000	120.0	3.048	640	16.26	960	24.38	-	-	-	-	-	-

LU9235

The screen aspect ratio is 16:10 and the projected picture is 16:10.

Lens										Wide Zoom (LS2ST1)				Standard (LS2SD2)			
Throw ratio										1.1~1.3				1.54~1.93			
Diagonal		Image Width		Image Height		Offset (A)		O		Distance				Distance			
						Wide/Tele		Wide/Tele		Wide		Wide		Wide		Wide	
(Inch)	(m)	(Inch)	(m)	(Inch)	(m)	(Inch)	(m)	(Inch)	(m)	(Inch)	(m)	(Inch)	(m)	(Inch)	(m)	(Inch)	(m)
80	2.03	68	1.72	42	1.08	2.1	0.054	23.3	0.592	75	1.90	88	2.24	104	2.65	131	3.33
100	2.54	85	2.15	53	1.35	2.6	0.067	29.1	0.740	93	2.37	110	2.80	131	3.32	164	4.16
120	3.05	102	2.58	64	1.62	3.2	0.081	35.0	0.888	112	2.84	132	3.36	157	3.98	196	4.99
150	3.81	127	3.23	79	2.02	4.0	0.101	43.7	1.111	140	3.55	165	4.20	196	4.98	245	6.24
200	5.08	170	4.31	106	2.69	5.3	0.135	58.3	1.481	187	4.74	220	5.60	261	6.63	327	8.31
300	7.62	254	6.46	159	4.04	7.9	0.202	87.4	2.221	280	7.11	331	8.40	-	-	-	-
400	10.16	339	8.62	212	5.38	10.6	0.269	116.6	2.962	-	-	-	-	-	-	-	-

Lens										Semi Long (LS2LT1)				Long Zoom (LS2LT2)				Wide Fix (LS2ST3)	
Throw ratio										1.93~2.9				3~5				0.778	
Diagonal		Image Width		Image Height		Offset (A)		O		Distance				Distance				Distance	
						Wide/Tele		Wide/Tele		Wide		Wide		Wide		Wide		NA	
(Inch)	(m)	(Inch)	(m)	(Inch)	(m)	(Inch)	(m)	(Inch)	(m)	(Inch)	(m)	(Inch)	(m)	(Inch)	(m)	(Inch)	(m)	(Inch)	(m)
80	2.03	68	1.72	42	1.08	2.1	0.054	23.3	0.592	131	3.33	197	5.00	204	5.17	339	8.62	53	1.34
100	2.54	85	2.15	53	1.35	2.6	0.067	29.1	0.740	164	4.16	246	6.25	254	6.46	424	10.77	66	1.68
120	3.05	102	2.58	64	1.62	3.2	0.081	35.0	0.888	196	4.99	295	7.50	305	7.75	509	12.92	79	2.01
150	3.81	127	3.23	79	2.02	4.0	0.101	43.7	1.111	245	6.24	369	9.37	382	9.69	636	16.15	99	2.51
200	5.08	170	4.31	106	2.69	5.3	0.135	58.3	1.481	327	8.31	492	12.49	509	12.92	848	21.54	132	3.35
300	7.62	254	6.46	159	4.04	7.9	0.202	87.4	2.221	491	12.47	738	18.74	763	19.39	1272	32.31	-	-
400	10.16	339	8.62	212	5.38	10.6	0.269	116.6	2.962	655	16.63	984	24.99	-	-	-	-	-	-

 **Note:**

There is 5% tolerance among these numbers due to optical component variations. BenQ recommends that if you intend to permanently install the projector, you should physically test the projection size and distance using the actual projector before you permanently install it, so as to make allowance for this projector's optical characteristics. This will help you determine the exact mounting position so that it best suits your installation location.

Lens dimension

Optional Lens (Wide Fix: LS2ST3)

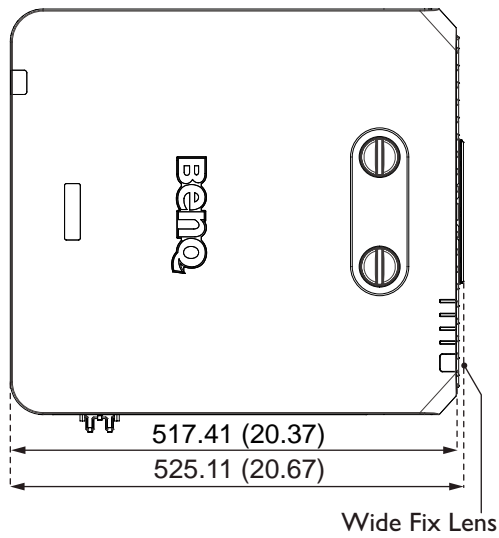

Optional Lens (Wide Zoom: LS2ST1)

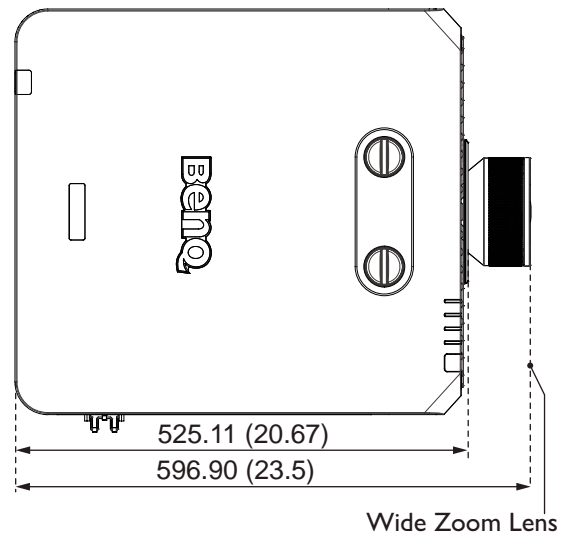

Optional Lens (Standard: LS2SD2)

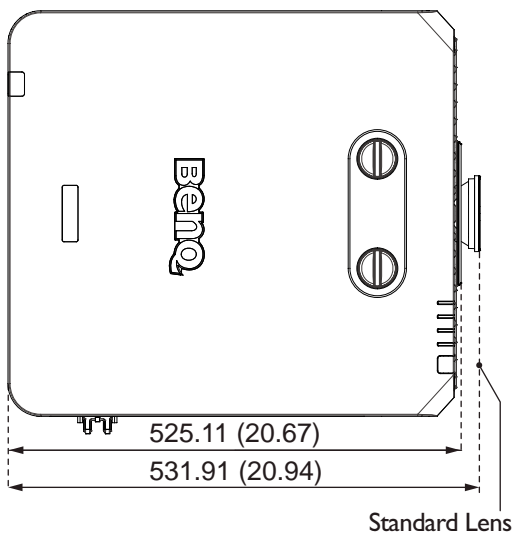

Optional Lens (Semi Long Throw: LS2LT1)

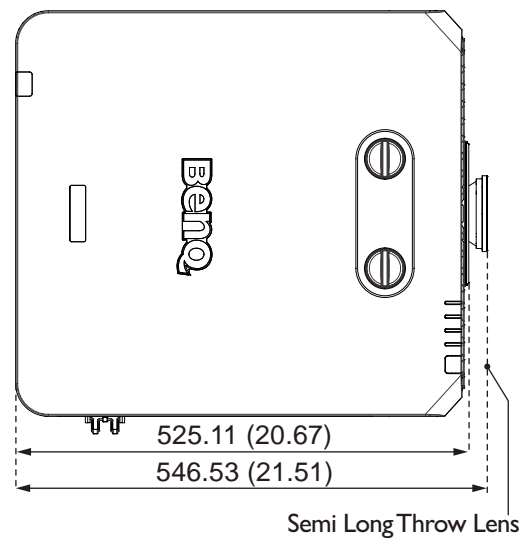

Optional Lens (Long Zoom: LS2LT2)

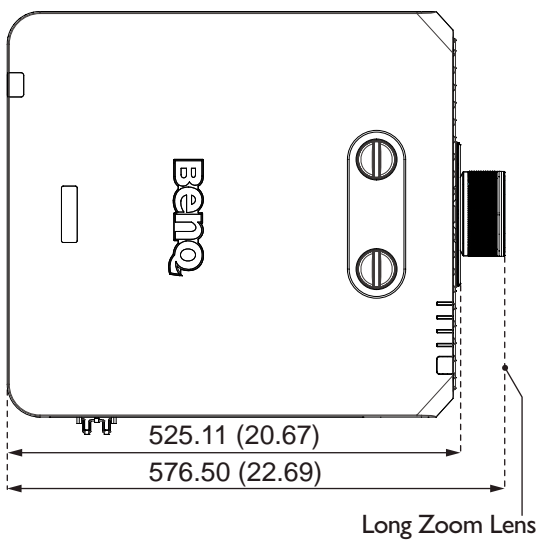

Adjusting by Lens shift

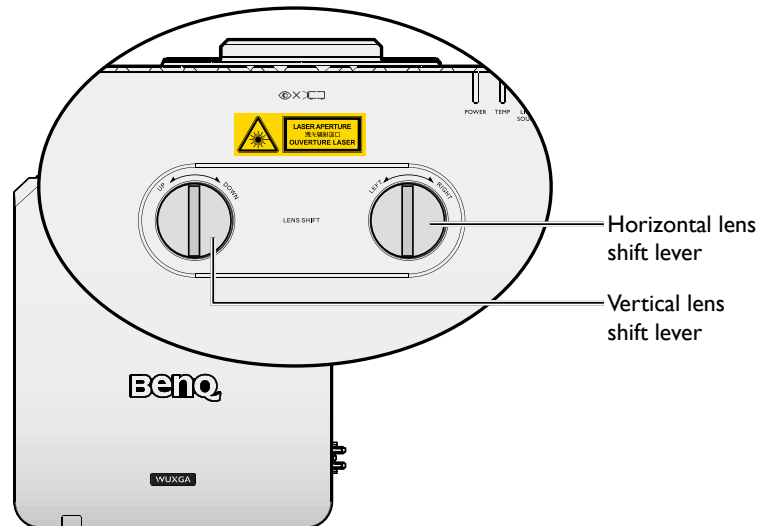

The Lens Shift function can be used to adjust the position of the projected image either horizontally or vertically within the range detailed below.

Adjusting the vertical image position

The vertical image height can be adjusted between 50% and -10% for XGA, 55% and -15% for WUXGA of offset position. Please consult the Lens Shift Range diagram below for further clarification.

Adjusting the horizontal image position

With the lens in the center position the horizontal image position can be adjusted to the left or right by up to a maximum of 5% of the image width. Please consult the Lens Shift Range diagram below for further clarification.

Lens shift range diagram

LX9215

Desk-Front Projection

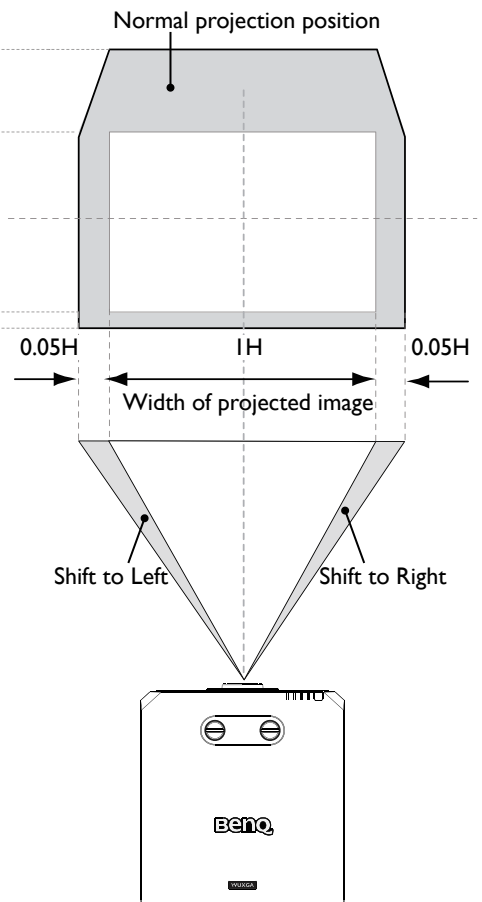
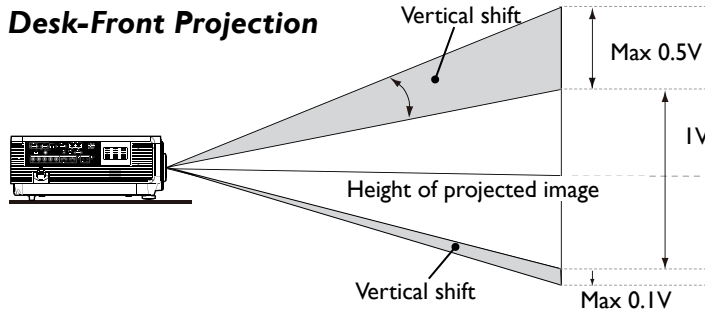

Ceiling Mount-Front Projection

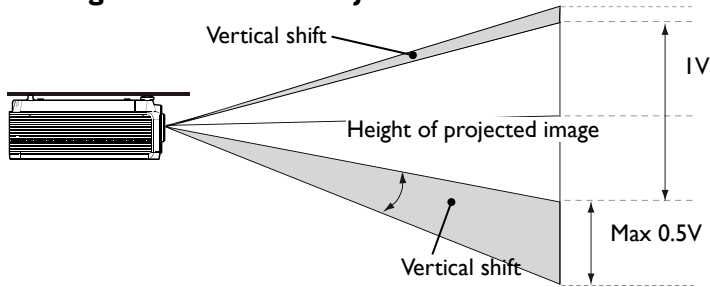

LU9235

Desk-Front Projection

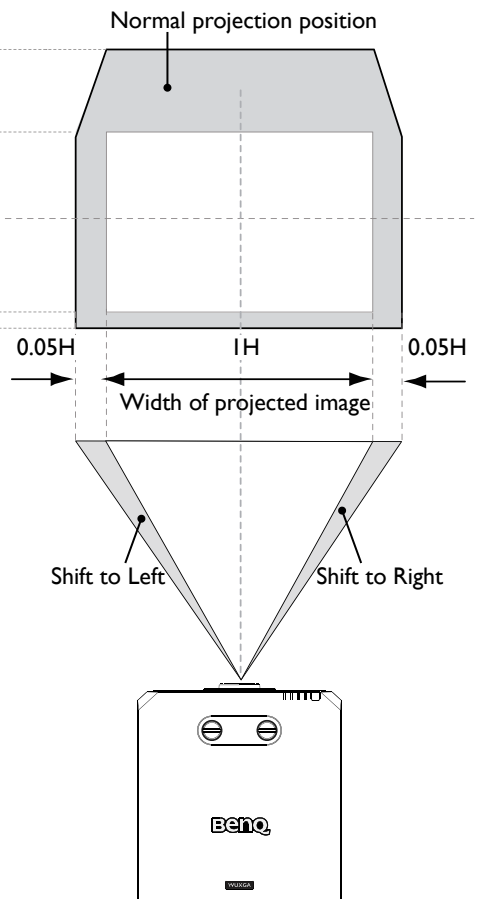
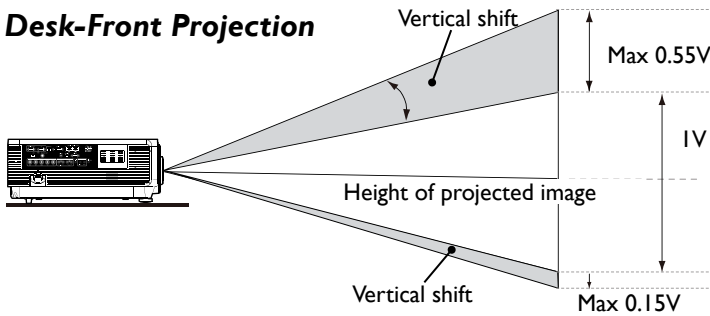

Ceiling Mount-Front Projection

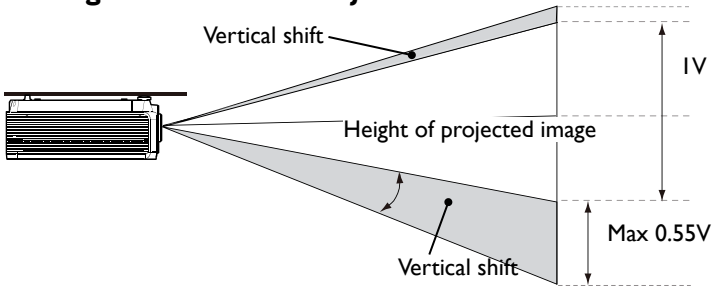

Notice (when edge blending)

- To avoid the image shaking or some pixels in the display may be misaligned, do not use the projector in the following location:
 - In a building close to a construction site.
 - In a room where an air conditioner unit is working and it vibrates.
 - In a place where the temperature changes dramatically that may cause thermal contraction.
- Before making any adjustment, leave the projector lit for at least 45 minutes after its light source is turned on. This allows the internal temperature of the projector to stabilize.

Adjusting the Zoom/Focus

You may turn the zoom ring to zoom in or out. To focus the image, rotate the focus ring until the image is clear. The projector will focus at distances. See page 23.

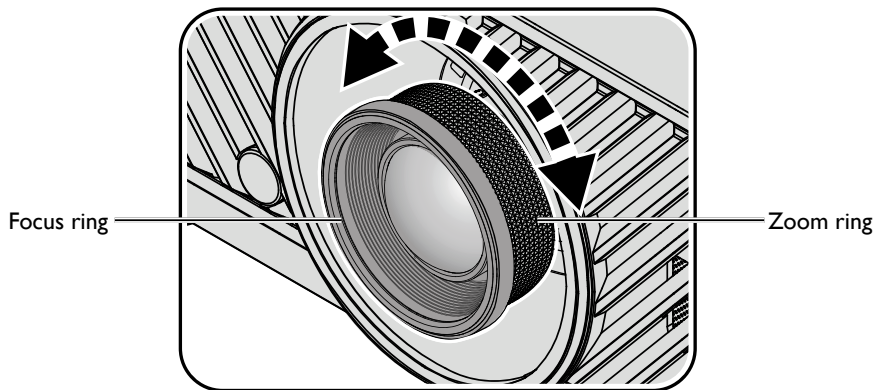

Connection

Before connecting

- Before connecting, carefully read the operating instructions for connecting the external device
- Turn off the power to all devices before connecting cables.
- Take note of the following before connecting cables. Failure to do so may result in malfunctions.
 - Before connecting a cable to the projector or to a device that is connected to the projector, touch any nearby metallic objects to remove any static electricity from your body.
 - Do not use unnecessarily long cables to connect the projector or a device to the projector. Using a longer cable that is wound makes it act like an antenna, making it more susceptible to noise.
 - When connecting cables, connect GND first and then insert the connecting terminal of the connecting device.
- Acquire any connection cables necessary to connect external devices to the system that are not supplied.
- The images on the screen may wobble if the video signal contains too much jitter. In this case, a time base corrector (TBC) must be connected.
- If synchronization signal outputs from computers or video equipment are disrupted due to changes in the video output settings or any other reasons, the colors of projected images may be temporarily disrupted.
- The projector accepts video signals, Y/C signals, YCBCR/YPBPR signals, analog RGB signals (synchronization signals are TTL level), and digital signals.
- Some computer models are not compatible with the projector.
- Use a cable compensator when you connect devices to the projector with long cables. If a cable compensator is not used, the image may not display properly.

PC

No.	Serial
1	R/PR
2	G/Y
3	B/PB
4	-
5	GND
6	GND
7	GND
8	GND

No.	Serial
9	-
10	GND
11	GND
12	DDC data
13	SYNC/HD
14	VD
15	DDC clock

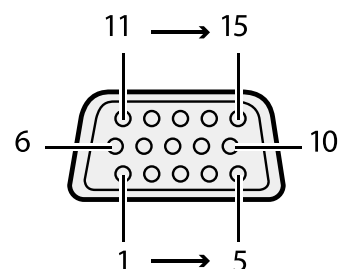

HDMI I

No.	Serial
1	TMDS Data2+
2	TMDS Data2 Shield
3	TMDS Data2-
4	TMDS Data1+
5	TMDS Data1 Shield
6	TMDS Data1-
7	TMDS Data0+
8	TMDS Data0 Shield
9	TMDS Data0-
10	TMDS Clock+

No.	Serial
11	TMDS Clock Shield
12	TMDS Clock-
13	CEC
14	Reserved (N.C. on device)
15	SCL
16	SDA
17	DDC/CEC Ground
18	+5 V Power (max 50 mA)
19	Hot Plug Detect

Even-numbered pins of 2 to 18

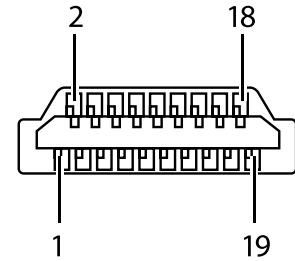

Odd-numbered pins of 1 to 19

DVI-D

No.	Serial
1	T.M.D.S data 2-
2	T.M.D.S data 2+
3	T.M.D.S data 2/4 shield
4	-
5	-
6	DDC clock
7	DDC data
8	-
9	T.M.D.S data 1-
10	T.M.D.S clock1+
11	T.M.D.S data 1/3 shield
12	-

No.	Serial
13	-
14	-+5 V
15	GND
16	Hot plug detection
17	T.M.D.S data 0-
18	T.M.D.S data 0+
19	T.M.D.S data 0/5 shield
20	-
21	-
22	T.M.D.S clock shield
23	T.M.D.S clock+
24	T.M.D.S clock-

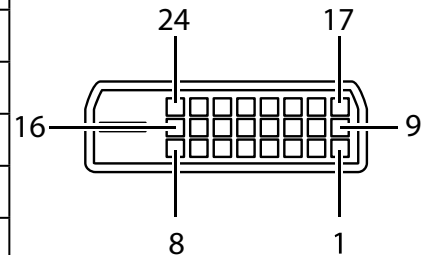

Connecting with AV equipment

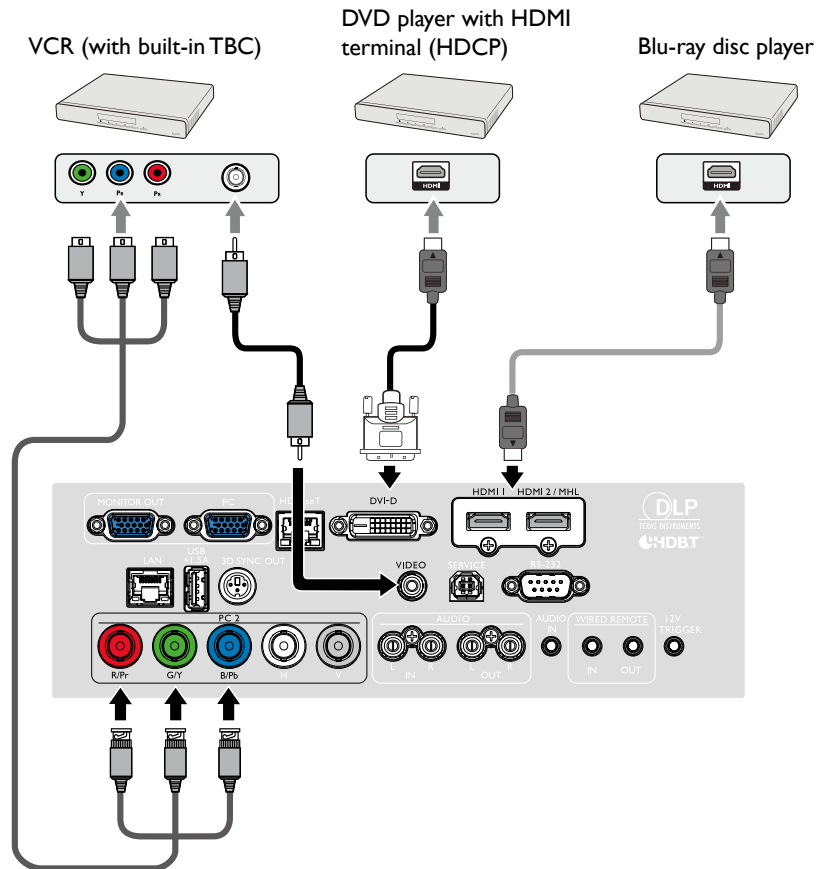

Connecting with computer

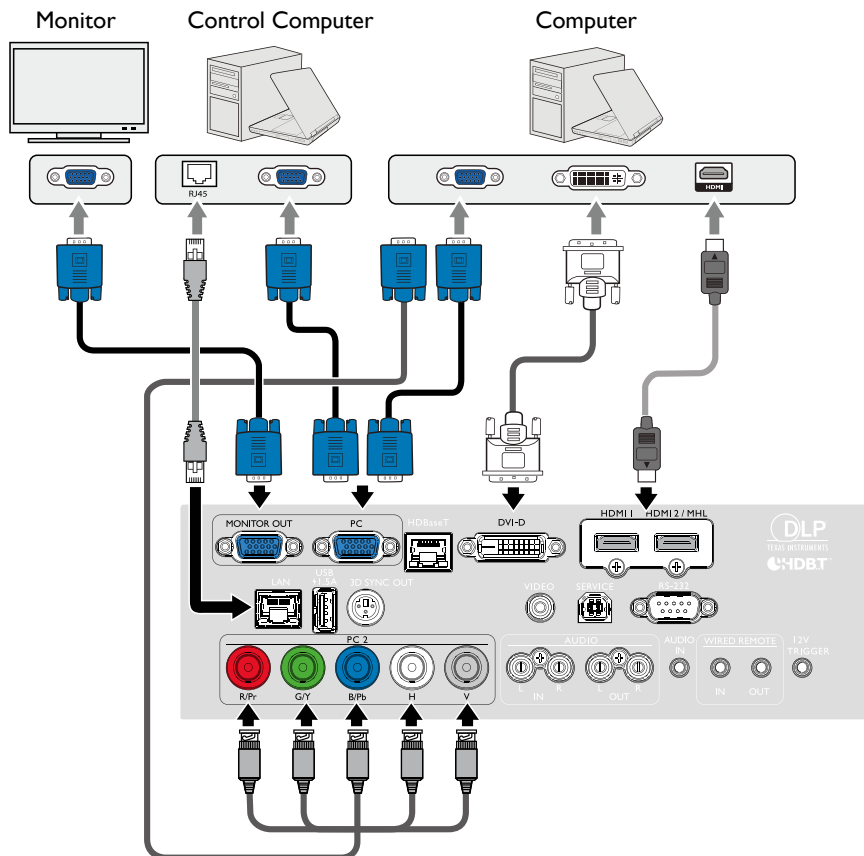

Connecting with HDBaseT transmitter

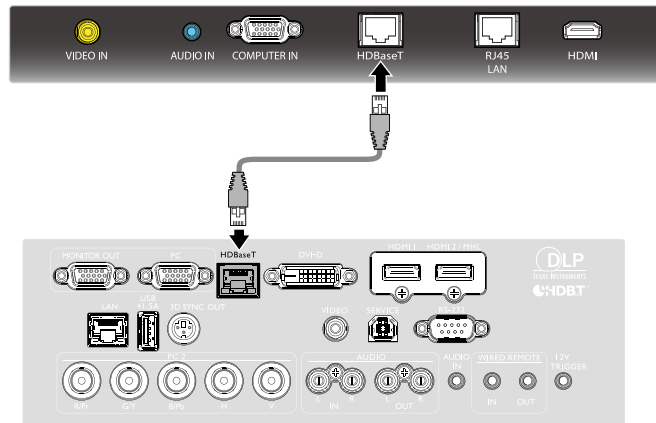

Projector connecting terminals

Connecting with LAN

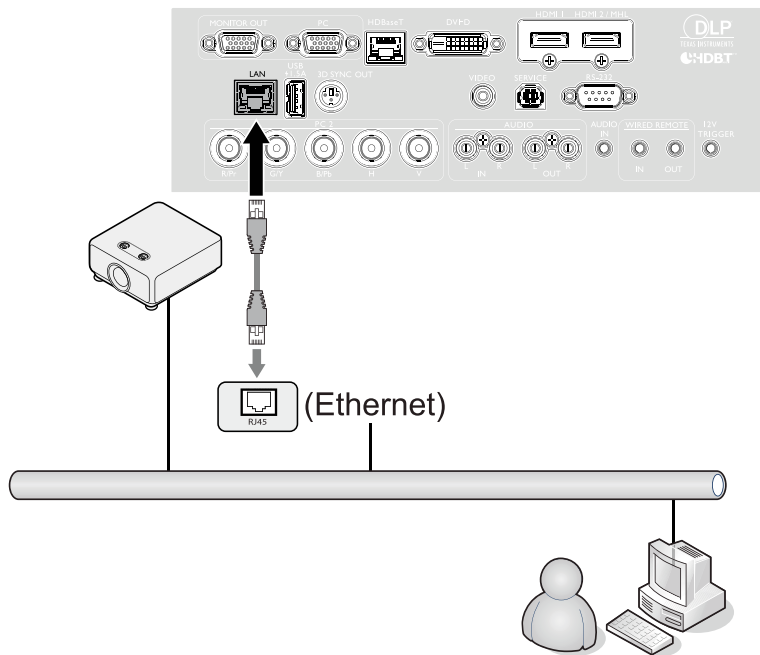

Operations

Switch on/off the projector

Connecting the power cord

Plug the power cord into the projector and into a wall socket. Turn on the wall socket switch (where fitted). Check that the POWER indicator light on the projector lights orange after power has been applied.

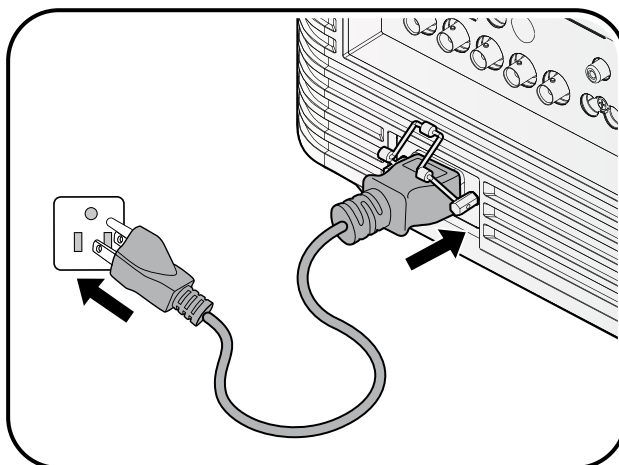

Caution:

Please use the original accessories (e.g. power cable) only with the device to avoid possible dangers such as electric shock and fire.

Power indicator

Power	Temp	Light	Filter	Status & Description
Orange	-	-	-	Stand-by
Green Flashing	-	-	-	Powering up
Green	-	-	-	Normal operation
Orange Flashing	-	-	-	Normal power down cooling

Switch on the projector

Press **POWER** on the projector or **ON** on the remote control to start the projector and a start up tone sounds. The **POWER** indicator light flashes green and stays green when the projector is on.

The start up procedure takes about 30 seconds. In the later stage of start up, a startup logo is projected.

(If necessary) Rotate the focus ring to adjust the image clearness.

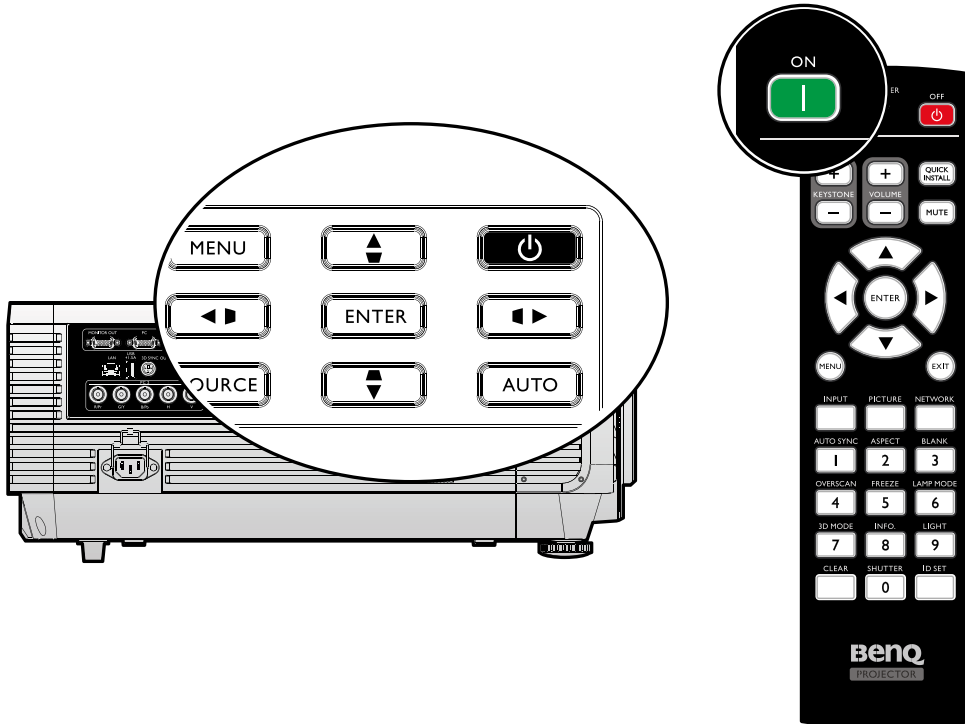

Select language

To use the OSD menus, please set them to your familiar language first.

Please select language			
English	한국어	Hrvatski	हिन्दी
Français	Svenska	Română	
Deutsch	Nederlands	Norsk	
Italiano	Türkçe	Dansk	
Español	Čeština	Български	
Русский	Português	suomi	
繁體中文	ไทย	Indonesian	
简体中文	Polski	Ελληνικά	
日本語	Magyar	العربية	
Press Enter to confirm, Exit to leave			

*After this process is done, this menu will not show up again after 1st time adjustment unless user presses **Reset All Settings**.

- I. Press **ENTER** on the projector or remote control to turn the OSD menu on.



2. Use ◀/▶ to highlight the **System Setup: Basic** menu.

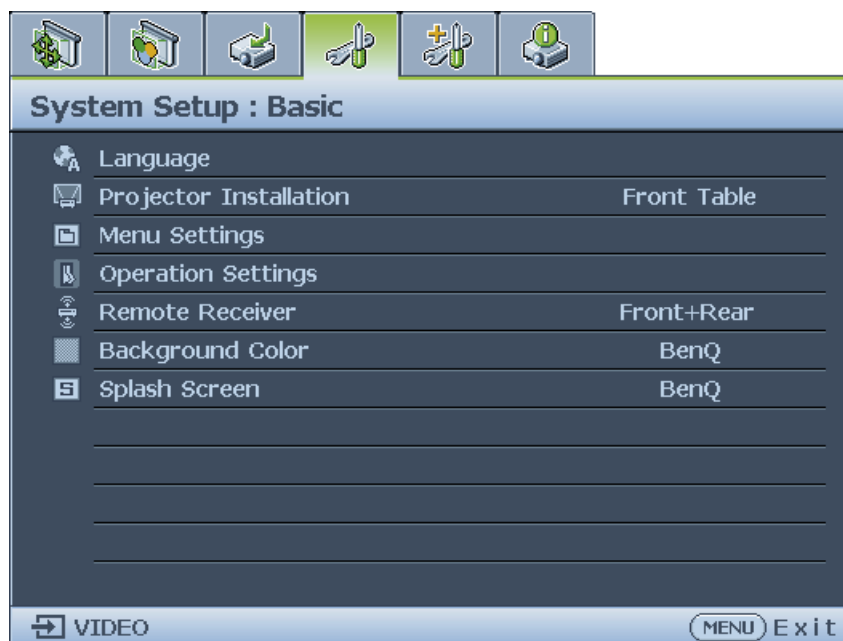

3. Press ▼ to highlight **Language** and press **ENTER** to select a preferred language.



4. Press **ENTER** twice* on the projector or remote control to leave and save the settings.

*The first press leads you back to the main menu and the second press closes the OSD menu.

Using the OSD

Choosing a location

Your projector is designed to be installed in one of four possible installation locations:

1. Front Table

Select this location with the projector placed on a table in front of the screen. This is the most common way to position the projector for quick setup and portability.

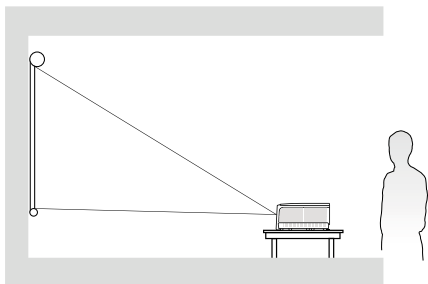

2. Rear Table

Select this location with the projector placed on a table behind the screen. Note that a special rear projection screen is required.

*Set **Rear Table** in the **SYSTEM SETUP: Basic > Projector Installation** menu after you turn the projector on.

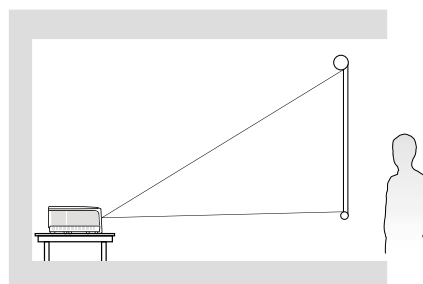

3. Front Ceiling

Select this location with the projector suspended upside-down from the ceiling in front of the screen.

Purchase the BenQ Projector Ceiling Mounting Kit from your dealer to mount your projector on the ceiling.

*Set **Front Ceiling** in the **SYSTEM SETUP: Basic > Projector Installation** menu after you turn the projector on.

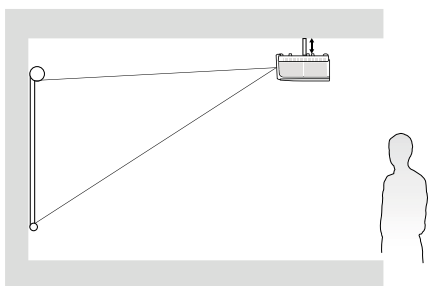

4. Rear Ceiling

Select this location with the projector suspended upside-down from the ceiling behind the screen.

Note that a special rear projection screen and the BenQ Projector Ceiling Mounting Kit are required for this installation location.

*Set **Rear Ceiling** in the **SYSTEM SETUP: Basic > Projector Installation** menu after you turn the projector on.

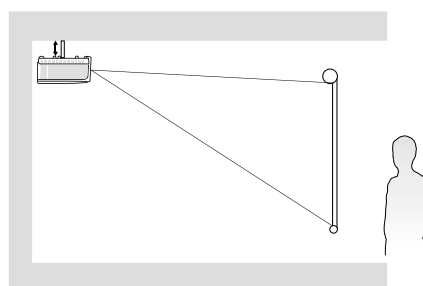

Your room layout or personal preference will dictate which installation location you select. Take into consideration the size and position of your screen, the location of a suitable power outlet, as well as the location and distance between the projector and the rest of your equipment.

Using test pattern

The projector is capable of displaying the grid test pattern. It can be used to assist you with the adjustment of image size and focus, ensuring that the projected image is free from distortion. To display the test pattern, open the OSD menu and go to the **System Setup: Advanced > Test Pattern** and press ◀/▶ to select On.

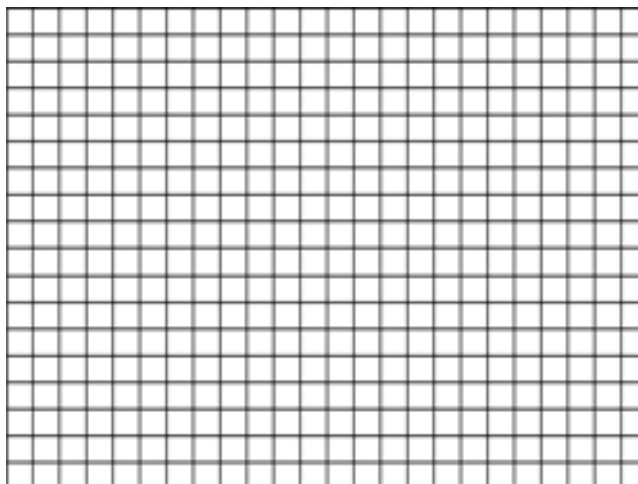

Adjusting by corner fit

Manually adjust four corners of the image by setting the horizontal and vertical values. Using the OSD menu

1. Press **MENU** and then press ◀/▶ until the **Display** menu is highlighted.
2. Press ▼ to highlight **Corner Fit** and press **ENTER**. The **Corner Fit** page displays.



3. Press ▲/▼/◀/▶ to select one of the four corners and press **ENTER**.

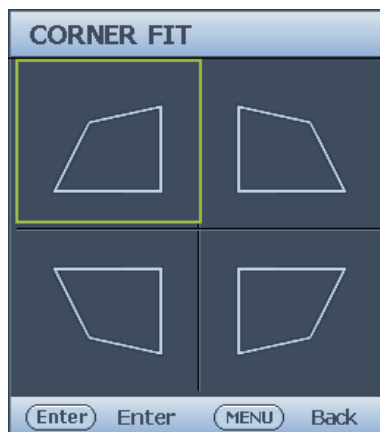

4. Press ▲/▼ to adjust vertical values from 0 to 60.

5. Press ◀/▶ to adjust horizontal values from 0 to 60.

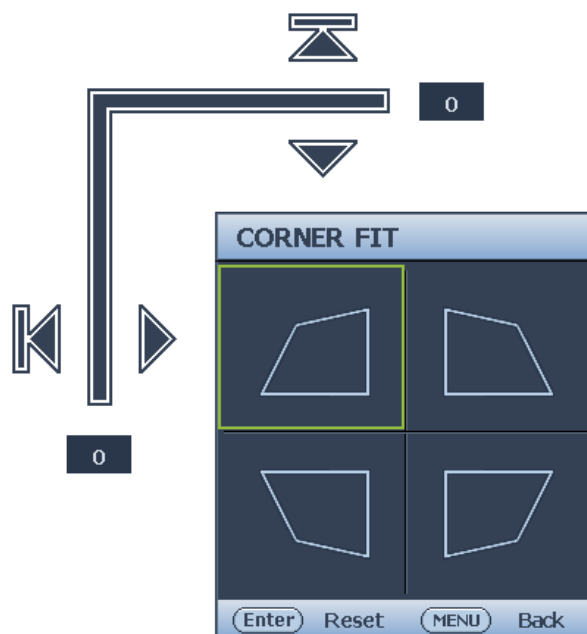

Auto adjusting the image

In some cases, you may need to optimize the picture quality. To do this, press **AUTO** on the projector or remote control. Within 3 seconds, the built-in Intelligent Auto Adjustment function will re-adjust the values of Frequency and Clock to provide the best picture quality. The current source information will be displayed in the upper left corner of the screen for 3 seconds.

Note:

- The screen will be blank while AUTO is functioning.
- This function is only available when PC signal (analog RGB) is selected.

Fine turning the image size and clarity

1. Adjust the projected image to the size that you need using the ZOOM ring.
2. Sharpen the image by rotating the FOCUS ring.

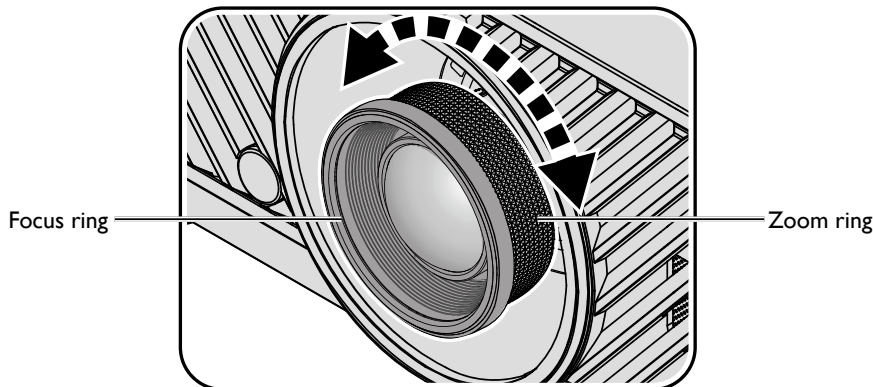

Switch off the projector

1. Press **POWER** or **OFF** and a confirmation message will appear prompting you. If you don't respond in a few seconds, the message will disappear.
2. Press **POWER** or **OFF** a second time. The **POWER** indicator light flashes orange, the projection light source shuts down.

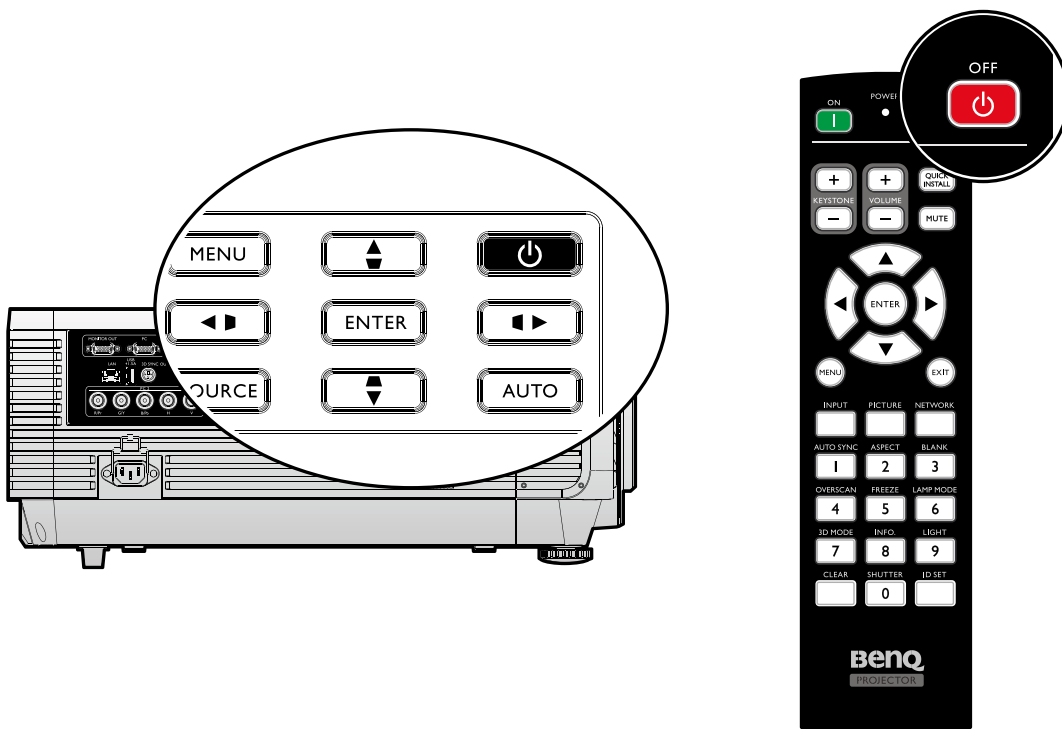

3. Once the cooling process finishes, a "**Power Off Ring Tone**" will be heard. The **POWER** indicator light is a steady orange and fans stop. Disconnect the power cord from the power outlet.

Caution:

- To protect the light source, the projector will not respond to any commands during the cooling process.
- Press **POWER** or **ON** again to start the projector after the **POWER** indicator light turns orange.

Using the menu

Main menu

The projector is equipped with On-Screen Display (OSD) menus for making various adjustments and settings.

Below is the overview of the OSD menu.



1. Display menu (see "Display menu" on page 42)
2. Picture menu (see "Picture menu" on page 45)
3. Source menu (see "Source menu" on page 49)
4. System Setup : Basic menu (see "System setup : Basic menu" on page 50)
5. System Setup : Advanced menu (see "System setup : Advanced menu" on page 52)
6. Information menu (see "Information menu" on page 57)

Available menu items may vary depending on the connected video sources or specified settings. Menu items that are not available will become grayed out.

- Use the arrow keys (**▲/▼/◀/▶**) on the projector or remote control to move through the menu items.
- Use **ENTER** to confirm the selected menu item.

Display menu



- **Aspect Ratio**

Press ◀/▶ to adjust the aspect of the projected image. The options are Auto, Real, 4:3, 16:9 and 16:10.

- Using the remote control

1. Press **ASPECT** to show the current setting.
2. Press **ASPECT** repeatedly to select an aspect ratio to suit the format of the video signal and your display requirements.

1. **Auto:** Scales an image proportionally to fit the projector's native resolution in its horizontal width. This is suitable for the incoming image which is neither in 4:3 nor 16:9 and you want to make most use of the screen without altering the image's aspect ratio.

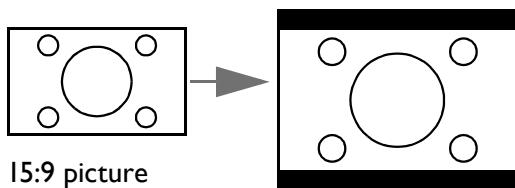

2. **Real:** The image is projected as its original resolution, and resized to fit within the display area. For input signals with lower resolutions, the projected image will display smaller than if resized to full screen. You could adjust the zoom setting or move the projector away from the screen to increase the image size if necessary. You may also need to refocus the projector after making these adjustments.

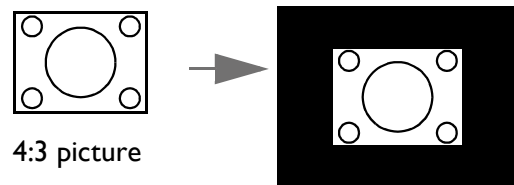

3. **4:3:** Scales an image so that it is displayed in the center of the screen with a 4:3 aspect ratio. This is most suitable for 4:3 images like computer monitors, standard definition TV and 4:3 images aspect DVD movies, as it displays them without aspect alteration.

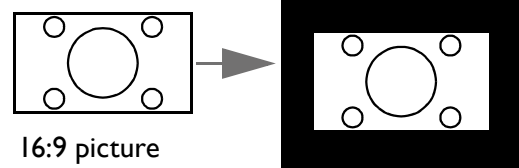
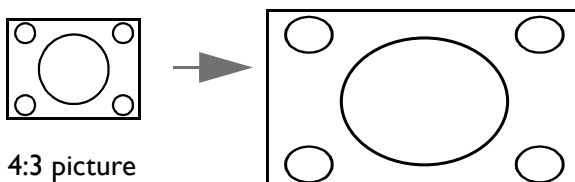

4. **16:9:** Scales an image so that it is displayed in the center of the screen with a 16:9 aspect ratio. This is most suitable for images which are already in a 16:9 aspect, like high definition TV, as it displays them without aspect alteration.

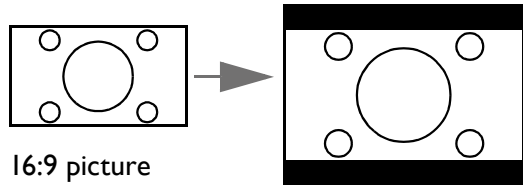

5. **16:10:** Scales an image so that it is displayed in the center of the screen with a 16:10 aspect ratio. This is most suitable for images which are already in a 16:10 aspect, as it displays them without aspect alteration.

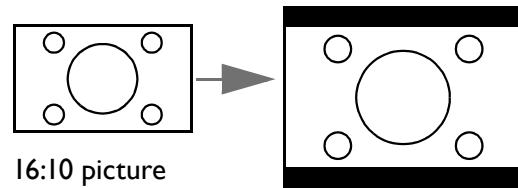

- **2D Keystone**
Press **ENTER** and press ▲/▼/◀/▶ to adjust horizontal or vertical distortion brought by the projection angle.
- **Corner Fit**
Press **ENTER** to enter the **Corner Fit** menu. See "[Corner Fit menu](#)" on page 44 for more details.
- **Position**
Press **ENTER** and press ▲/▼/◀/▶ to adjust the position of the projected picture.
- **Phase**
Press ◀/▶ to adjust Phase for the projected picture.
- **H. Size**
Press ◀/▶ to adjust H. Size for the projected picture.
- **Digital Zoom**
Press ◀/▶ to enlarge the projected image.
- **Overscan**
Press ◀/▶ to hide edge of the projected image to damage the noise appear.
- **3D**
Press **ENTER** to enter the **3D** menu. See "[3D menu](#)" on page 44 for more details.

Corner Fit menu

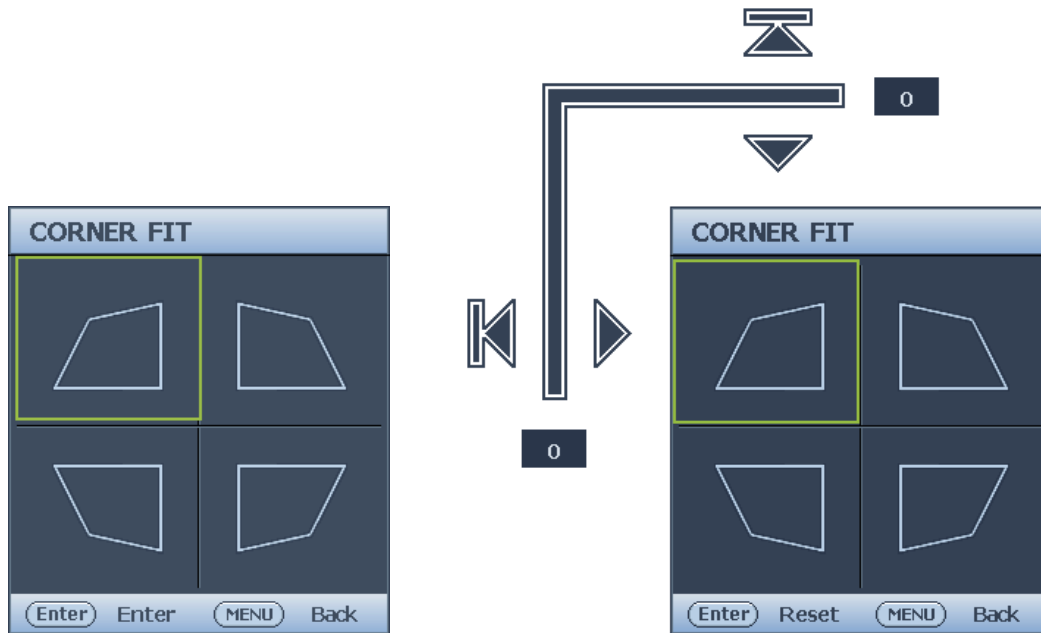

- **Top Left**
Press **ENTER** and press **▲/▼/◀/▶** to correct the top left corner.
- **Top Right**
Press **ENTER** and press **▲/▼/◀/▶** to correct the top right corner.
- **Bottom Left**
Press **ENTER** and press **▲/▼/◀/▶** to correct the bottom left corner.
- **Bottom Right**
Press **ENTER** and press **▲/▼/◀/▶** to correct the bottom right corner.

3D menu

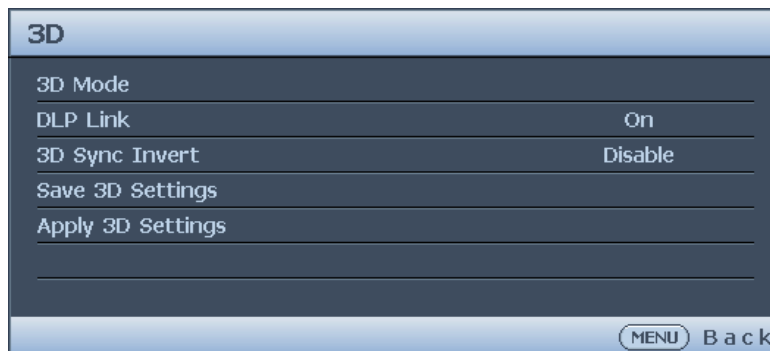

- **3D Mode**
Press **ENTER** to enter the **3D Mode** menu. Press **▲/▼** to select the 3D format. The options are Auto, Top Bottom, Frame Sequential, Frame Packing, Side by Side and Off.
- **DLP Link**
Press **◀/▶** to disable or enable DLP Link sync. The options are On and Off.
- **3D Sync Invert**
Press **◀/▶** to enable or disable 3D Sync Invert.
- **Save 3D Settings**
Press **ENTER** to enter the **Save 3D Settings** menu. Press **▲/▼** and **ENTER** to save the current 3D settings.
- **Apply 3D Settings**
Press **ENTER** to enter the **Apply 3D Settings** menu. Press **▲/▼** and **ENTER** to apply the saved 3D settings.

Picture menu

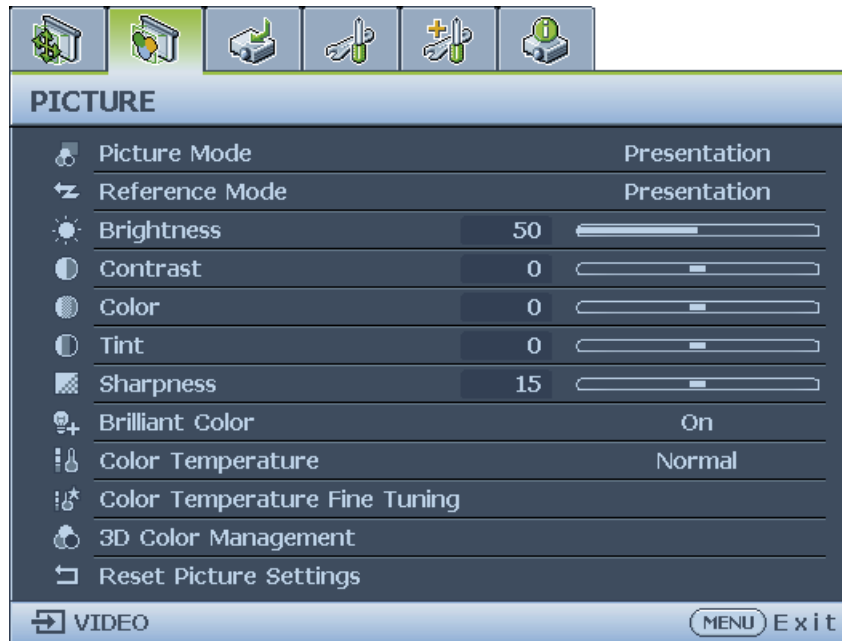

- **Picture Mode**

Press ◀/▶ to select a picture mode. The options are Bright, Presentation, sRGB, Cinema, DICOM SIM, 3D, User 1 and User 2.

- **Bright mode:** Maximizes the brightness of the projected image. This mode is suitable for environments where extra-high brightness is required, such as using the projector in well lit rooms.
- **Presentation mode:** Is designed for presentation. The brightness is emphasized in this mode to match PC and notebook coloring.
- **sRGB mode:** Maximizes the purity of RGB colors to provide true-to-life images regardless of brightness setting. It is most suitable for viewing photos taken with an sRGB compatible and properly calibrated camera, and for viewing PC graphic and drawing applications such as AutoCAD.
- **Cinema mode:** Is appropriate for playing colorful movies, video clips from digital cameras or DVs through the PC input for best viewing in a blackened (dimly lit) environment.
- **DICOM SIM:** This display mode simulates the grayscale/gamma performance of equipment used for “Digital Imaging and Communications in Medicine” (DICOM).
Important: This mode should NEVER be used for medical diagnosis, it is for education/training purposes only.
- **3D mode:** Is appropriate for playing 3D images and 3D video clips.
- **User 1/User 2 mode:** Recalls the settings customized based on the current available picture modes.

- **Reference Mode**

Press ◀/▶ to select a reference mode. The options are Bright, Presentation, sRGB, Cinema, DICOM SIM and 3D.

- **Brightness**

Press ◀/▶ to adjust the brightness of the projected image.

The higher the value, the brighter the image. And lower the setting, darker the image. Adjust this control so the black areas of the image appear just as black and that detail in the dark areas is visible.



- **Contrast**

Press ◀/▶ to adjust the contrast of the projected image.

The higher the value, the greater the contrast. Use this to set the peak white level after you have previously adjusted the Brightness setting to suit your selected input and viewing environment.

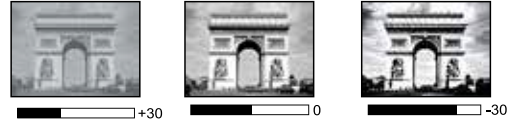

- **Color**

Press ◀/▶ to adjust the color saturation.

Lower setting produces less saturated colors. If the setting is too high, colors on the image will be overpowering, which makes the image unrealistic.

- **Tint**

Press ◀/▶ to adjust the tint of the projected image.

The higher the value, the more reddish the picture becomes. The lower the value, the more greenish the picture becomes.

- **Sharpness**

Press ◀/▶ to adjust the display sharpness of the projected image.

The higher the value, the sharper the picture becomes. The lower the value, the softer the picture becomes.

- **Brilliant Color**

Press ◀/▶ to adjust the brilliant color of the projected image.

This feature utilizes a new color-processing algorithm and system level enhancements to enable higher brightness while providing truer, more vibrant colors in picture. It enables a greater than 50% brightness increase in mid-tone images, which are common in video and natural scenes, so the projector reproduces images in realistic and true colors. If you prefer images with that quality, select **On**. If you don't need it, select **Off**.

When **Off** is selected, the **Color Temperature** function is not available.

- **Color Temperature**

Press ◀/▶ to adjust the color temperature. The options are Cool, Normal and Warm.

- **Cool:** makes the image appear bluish white.
- **Normal:** Maintains normal colorings for white.
- **Warm:** Makes images appear reddish white.

- **Color Temperature Fine Tuning**

Press **ENTER** to enter the **Color Temperature Fine Tuning** menu. See "[Color Temperature Fine Tuning menu](#)" on page 47 for more details.

- **3D Color Management**

Press **ENTER** to enter the **3D Color Management** menu. See "[3D Color Management menu](#)" on page 48 for more details.

- **Reset Picture Settings**

Press **ENTER** to enter the **Reset Picture Settings** menu. Press ▲/▼ and press **ENTER** to set to the default value.

- **Current:** Returns current picture mode to the factory preset settings.
- **All:** Returns all settings, except User 1/User 2 in the Picture menu to the factory preset settings.

Color Temperature Fine Tuning menu



- **R Gain**
Press ◀/▶ to adjust the Red Gain.
- **G Gain**
Press ◀/▶ to adjust the Green Gain.
- **B Gain**
Press ◀/▶ to adjust the Blue Gain.
- **R Offset**
Press ◀/▶ to adjust the Red Offset.
- **G Offset**
Press ◀/▶ to adjust the Green Offset.
- **B Offset**
Press ◀/▶ to adjust the Blue Offset.

To set a preferred color temperature:

1. Highlight **Color Temperature** and select **Warm**, **Normal** or **Cool** by pressing ◀/▶ on the projector or remote control.
2. Press ▼ to highlight **Color Temperature Fine Tuning** and press **ENTER**. The Color Temperature Fine Tuning page appears.
3. Press ▲/▼ to highlight the item you want to change and adjust the values by pressing ◀/▶.
 - **R Gain/G Gain/B Gain:** Adjusts the contrast levels of Red, Green, and Blue.
 - **R Offset/G Offset/B Offset:** Adjusts the brightness levels of Red, Green, and Blue.
4. Press **MENU** to exit and save the settings.

3D Color Management menu

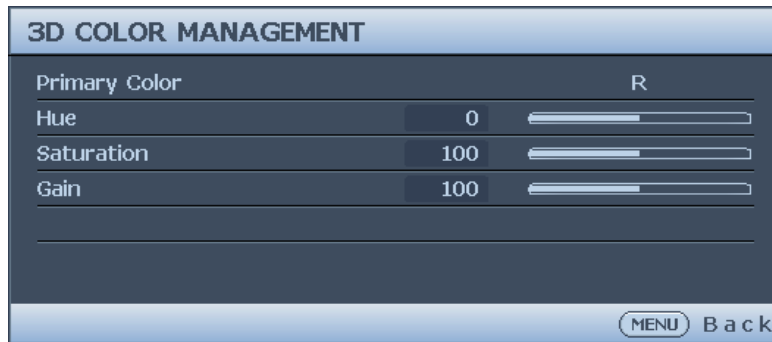

- **Primary Color**
Press **ENTER** to enter the **Primary Color** menu. Press **▲/▼** to select the primary color. The options are R, G, B, C, M and Y.
- **Hue**
Press **ENTER** to enter the **Hue** menu. Press **▲/▼/◀/▶** to adjust settings.
- **Saturation**
Press **ENTER** to enter the **Saturation** menu. Press **▲/▼/◀/▶** to adjust settings.
- **Gain**
Press **ENTER** to enter the **Gain** menu. Press **▲/▼/◀/▶** to adjust settings.

3D Color Management

In most installation situations, color management will not be necessary, such as in classroom, meeting room, or lounge room situations where lights remain on, or where building external windows allow daylight into the room.

Only in permanent installations with controlled lighting levels such as boardrooms, lecture theaters, or home theaters, should color management be considered. Color management provides fine color control adjustment to allow for more accurate color reproduction, should you require it.

Proper color management can only be achieved under controlled and reproducible viewing conditions. You will need to use a colorimeter (color light meter), and provide a set of suitable source images to measure color reproduction. These tools are not provided with the projector, however, your projector supplier should be able to provide you with suitable guidance, or even an experienced professional installer.

The Color Management provides six sets (RGBCMY) of colors to be adjusted. When you select each color, you can independently adjust its range and saturation according to your preference.

If you have purchased a test disc which contains various color test patterns and can be used to test the color presentation on monitors, TVs, projectors, etc. You can project any image from the disc on the screen and enter the 3D Color Management menu to make adjustments.

To adjust the settings:

1. Go to the **Picture** menu and highlight **3D Color Management**.
2. Press **ENTER** and the 3D Color Management page displays.
3. Highlight **Primary color** and press **◀/▶** to select a color from among Red, Green, Blue, Cyan, Magenta and Yellow.
4. Press **▼** to highlight **Hue** and press **◀/▶** to select its range. Increase in the range will

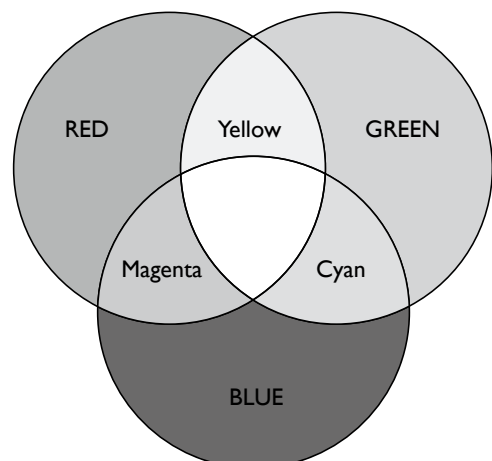

include colors consisted of more proportions of its two adjacent colors.

Please refer to the illustration to the right for how the colors relate to each other.

For example, if you select Red and set its range at 0, only pure red in the projected picture will be selected. Increasing its range will include red close to yellow and red close to magenta.

5. Press ▼ to highlight **Saturation** and adjust its values to your preference by press ◀/▶. Every adjustment made will reflect to the image immediately. For example, if you select Red and set its value at 0, only the saturation of pure red will be affected.

Source menu



- **Quick Auto Search**
Press ◀/▶ to enable or disable search the input source automatically.
- **Color Space Conversion**
Press ◀/▶ to select the color space. The options are Auto, RGB and YUV.

System setup : Basic menu



- Language**
 Press **ENTER** to enter the Language menu. Press **▲/▼/◀/▶** to select the language of OSD menu.
- Projector Installation**
 Press **◀/▶** to select the projector installation. The options are Front, Rear, Rear Ceiling and Front Ceiling.
- Menu Settings**
 Press **ENTER** to enter the **Menu Settings** menu. See "[Menu Settings menu](#)" on page 51 for more details.
- Operation Settings**
 Press **ENTER** to enter the **Operation Settings** menu. See "[Operation Settings menu](#)" on page 51 for more details.
- Remote Receiver**
 Press **◀/▶** to select the remote receiver. The options are Front, Rear and Front+Rear.
- Background Color**
 Press **◀/▶** to select the background color when no input signal. The options are BenQ, Black, Blue and Purple.
- Splash Screen**
 Press **◀/▶** to select the start up pattern when the projector turns on. The options are BenQ, Black and Blue.

Menu Settings menu

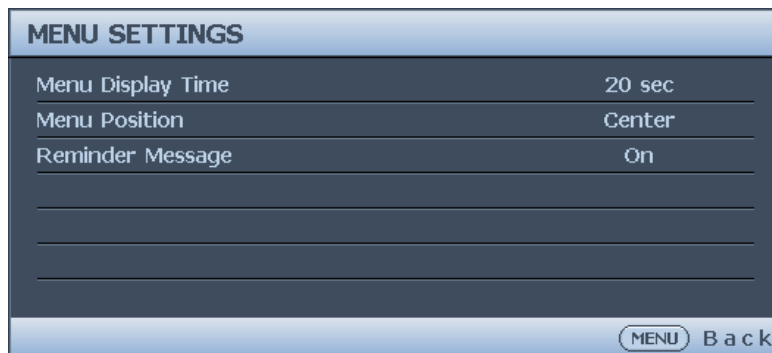

- **Menu Display Time**
Press ◀/▶ to select the menu display time period. The options are 5 sec, 10 sec, 20 sec, 30 sec and Always.
- **Menu Position**
Press ◀/▶ to select the menu display position. The options are Center, Top-Left, Top-Right, Bottom-Right and Bottom-Left.
- **Reminder Message**
Press ◀/▶ to enable or disable reminder message displays.

Operation Settings menu

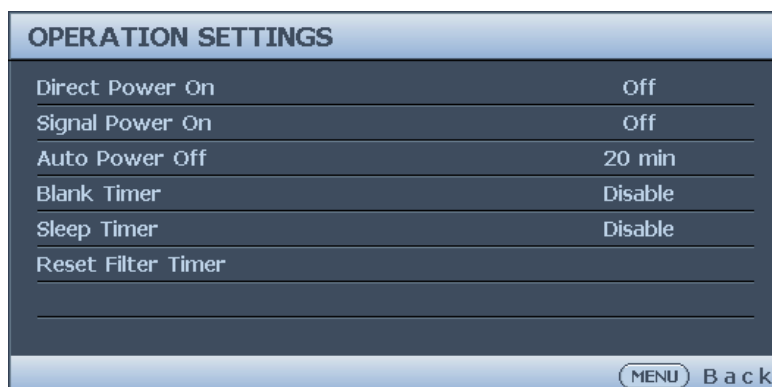

- **Direct Power On**
Press ◀/▶ to enable or disable automatically turning on the projector when the AC power is connected.
- **Signal Power On**
Press ◀/▶ to enable or disable automatically turning on the projector when an input signal is detected.
- **Auto Power Off**
Press ◀/▶ to enable or disable automatically turning off the projector when there is no input signal.
- **Blank Timer**
Press ◀/▶ to set the length of time the image is blanked. The options are Disable, 3 mins, 10 mins, 15 mins, 20 mins, 25 mins and 30 mins.
- **Sleep Timer**
Press ◀/▶ to set the length of time before the projector is turned off. The options are Disable, 5 mins, 10 mins, 15 mins, 20 mins, 25 mins and 30 mins.
- **Reset Filter Timer**
Press **ENTER** to reset the filter timer.

System setup :Advanced menu

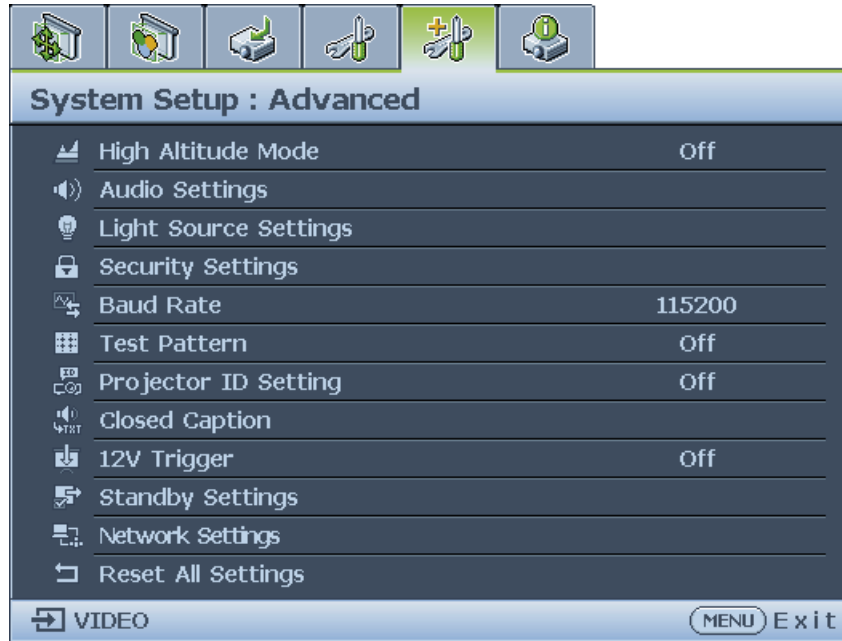

- High Altitude Mode**
 Press ◀/▶ to enable or disable High Altitude Mode. Enable this function when the operating altitude is higher than 1500m or the ambient temperature is over 40°C.
- Audio Settings**
 Press ENTER to enter the **Audio Settings** menu. See "Audio Settings menu" on page 53 for more details.
- Light Source Settings**
 Press ENTER to enter the **Light Source Settings** menu. See "Light Source Settings menu" on page 54 for more details.
- Security Settings**
 Press ENTER to enter the **Security Settings** menu. See "Security Settings menu" on page 54 for more details.
- Baud Rate**
 Press ◀/▶ to select RS-232 baud rate. The options are 2400, 4800, 9600, 14400, 19200, 38400, 57600 and 1152000.
- Test Pattern**
 Press ◀/▶ to select the test pattern. The options are Off, Grid, White, Red, Green, Blue, Black, RGB Ramps, Color Bar, Step Bars, CheckBoard, Horizontal Lines, Vertical Lines, Diagonal Lines, Horizontal Ramp and Vertical Ramps.
- Projector ID Setting**
 Press ◀/▶ to enable or disable the projector ID.
- Closed Caption**
 Press ENTER to enter the **Closed Caption** menu. See "Closed Caption menu" on page 55 for more details.
- 12 Trigger**
 Press ◀/▶ to enable or disable 12V trigger function.
- Standby Settings**
 Press ENTER to enter the **Standby Settings** menu. See "Standby Settings menu" on page 55 for more details.

- **Network Settings**
Press **ENTER** to enter the **Network Settings** menu. See "Network Settings menu" on page 56 for more details.
- **Reset All Settings**
Press **ENTER** to reset all settings to default value.

Audio Settings menu



- **Mute**
Press ◀/▶ to enable or disable the mute function.
 - Using the remote control
Press **MUTE** to temporarily turn off the sound. While the sound is off, the screen will display in the upper right corner of the screen.
To restore the sound, press **MUTE** again.
 - Using the OSD menu
 1. Press **MENU** and then press ◀/▶ until the **System Setup: Advanced** menu is highlighted.
 2. Press ▼ to highlight **Audio Settings** and press **ENTER**. The Audio Settings page displays.
 3. Highlight **Mute** and press ◀/▶ to select **On**.
 4. To restore the sound, repeat steps 1-3 and press ◀/▶ to select **Off**.
- **Volume**
Press ◀/▶ to adjust the volume of the projector.
 - Using the remote control
Press **VOLUME+/VOLUME-** to select a desired sound level.
 - Using the OSD menu
 1. Press **MENU** and then press ◀/▶ until the **System Setup: Advanced** menu is highlighted.
 2. Press ▼ to highlight **Audio Settings** and press **ENTER**. The Audio Settings page displays.
 3. Press ▼ to highlight **Volume** and press ◀/▶ to select a desired sound level.
- **Build-in speaker**
Press ◀/▶ to enable or disable the built-in speaker.
- **Power on/off Ring**
Press ◀/▶ to enable or disable sound when the projector turns on or off.

Note:

The only way to change Power on/off ring tone is setting On or Off here. Setting the sound mute or changing the sound level will not affect the Power on/off ring tone.

Light Source Settings menu

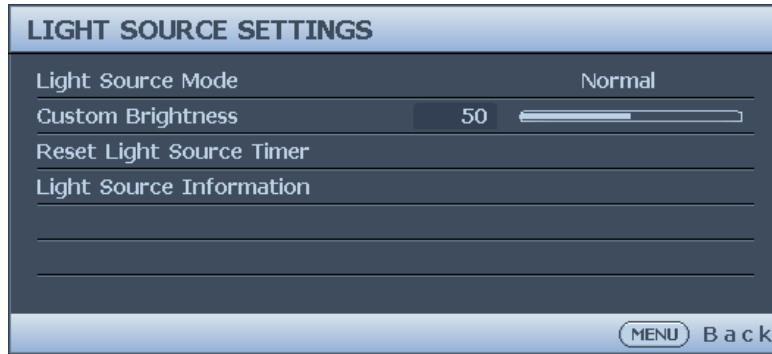

- **Light Source Mode**
Press ◀/▶ to select the light source mode. The options are Normal, Economic, Dimming and Custom.
- **Custom Brightness**
Press ◀/▶ to adjust the brightness of the projector.
- **Reset Light Source Timer**
Press **ENTER** to reset the light source timer.
- **Light Source Information**
Press **ENTER** to enter the Light Source Information menu.

Security Settings menu

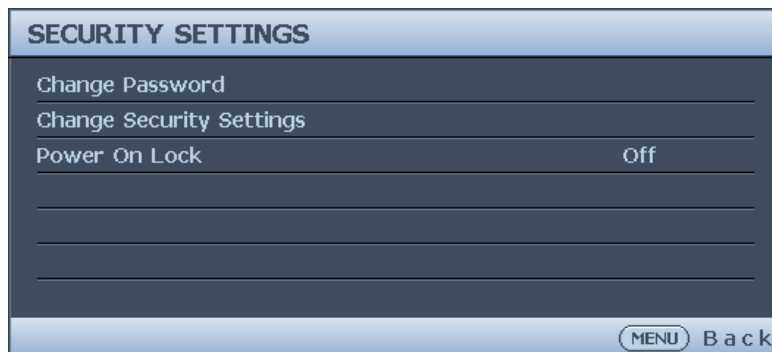

- **Change Password**
Press **ENTER** to change the password.
- **Change Security Settings**
Press **ENTER** to change the security settings.
- **Power On Lock**
Press ◀/▶ to enable or disable the power on lock function. If the function is enabled, you must enter the password every time the projector is turned on.

Closed Caption menu



- **Closed Caption Enable**
Press ◀/▶ to enable or disable the closed caption function.
- **Caption Version**
Press ◀/▶ to select the closed captioning mode. The options are CC1, CC2, CC3 and CC4.

Standby Settings menu

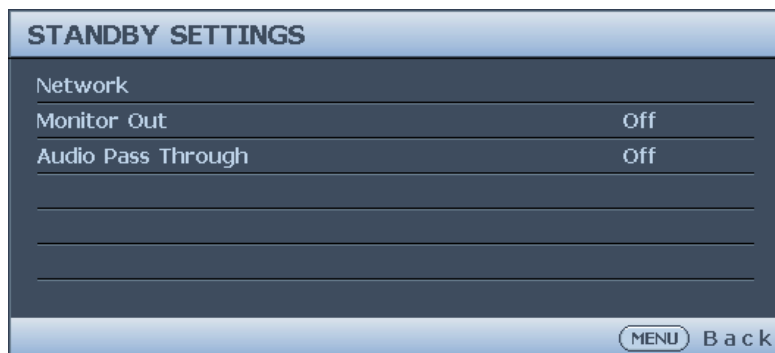

- **Network**
Press **ENTER** to enable the network function when the projector is in standby mode.
- **Monitor Out**
Press ◀/▶ to enable or disable the monitor out function when the projector is in standby mode.
- **Audio Pass Through**
Press ◀/▶ to enable the audio line-out function when the projector is in standby mode. The options are Audio In, Audio L/R, HDMI 1, HDMI 2 / MHL and Off.

Network Settings menu



- **Wired LAN**
Press **ENTER** to enter the **Wired LAN** menu to setup the IP address, subnet mask, default gateway, DNS server and DHCP.
- **AMX Device Discovery**
Press ◀/▶ to enable or disable the AMX device discovery function. When the function is enabled, the projector can be detected by an AMX controller.
- **Mac Address**
Displays the current MAC address of the projector.

Information menu

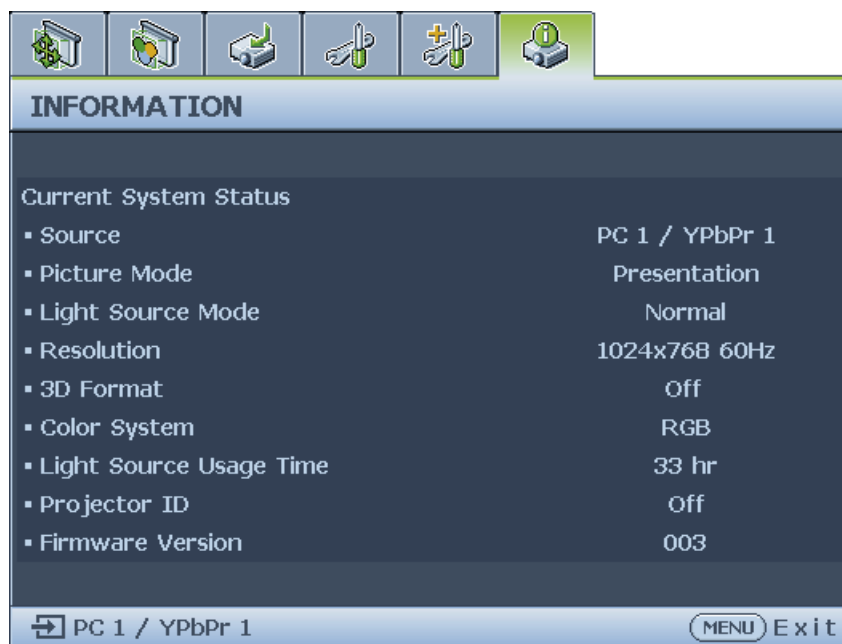

- **Source**
Displays the current signal source.
- **Picture Mode**
Displays the current picture mode.
- **Light Source Mode**
Displays the current light source mode.
- **Resolution**
Displays the native resolution of the input source.
- **3D Format**
Displays the current 3D mode. Only available when 3D Mode is enabled.
- **Color System**
Displays the input system format.
- **Light Source Usage Time**
Displays the number of hours the light source has been used.
- **Projector ID**
Displays the current projector ID.
- **Firmware Version**
Displays the firmware version of your projector.

Menu structure

Main menu	Sub-menu	Options	
Display	Aspect Ratio	Auto/ Real/ 4:3/ 16:9/ 16:10	
	2D Keystone		
	Corner Fit	Top Left/ Top Right/ Bottom Left/ Bottom Right	
	Position		
	Phase		
	H.size		
	Digital zoom	PC: 1.0X~2.0X Video: 1.0X~1.8X	
	Overscan	Composite/S-Video: 0- 3 others: 0-3	
	3D	3D mode	
		DLP Link	On/ Off
		3D Sync Invert	Disable/ Invert
		Save 3D Setting	3D Settings 1/ 3D Settings 2/ 3D Settings 3
		Apply 3D Setting	3D Settings 1/ 3D Settings 2/ 3D Settings 3
Picture	Picture Mode	Bright/ Presentation/ sRGB/ Cinema/ DISCOM/ 3D/ User 1/ User 2	
	Reference Mode	Bright/ Presentation/ sRGB/ Cinema/ DISCOM/ 3D	
	Brightness		
	Contrast		
	Color		
	Tint		
	Sharpness		
	Brilliant Color	On/ Off	
	Color Temperature	Cool/ Normal/ Warm	
	Color Temperature	R Gain/ G Gain/ B Gain/ R Offset/ G Offset/ B Offset	
	Fine Tuning		
	3D Color Management	Primary Color Hue Saturation Gain	
		R/ G/ B/ C/ M/ Y	
		Reset picture settings	Current/ All/ Cancel
Source	Quick Auto Search	On/ Off	
	Color Space Conversion	Auto/ RGB/ YUV	

Main menu	Sub-menu	Options	
System Setup: Basic	Language	English / Français / Deutsch / Italiano / Español / Русский / 繁體中文 / 简体中文 / 日本語 / 한국어 / Svenska / Nederlands / Türkçe / Čeština / Português / বাংলা / Polski / Magyar / Hrvatski / Română / Norsk / Dansk / Български / Suomi / Indonesian / Ελληνικά / العربية / हिन्दी	
	Projector Installation	Front / Rear / Rear Ceiling / Front Ceiling	
	Menu Setting	Menu Display Time	5 sec / 10 sec / 20 sec / 30 sec / Always
		Menu Position	Center / Top-Left / Top-Right / Bottom-Right / Bottom-Left
	Operation Setting	Reminder Message	On / Off
		Direct Power On	On / Off
		Signal Power On	On / Off
		Auto Power Off	Disable / 3 mins / 10 mins / 15 mins / 20 mins / 25 mins / 30 mins
		Blank Timer	Disable / 5 mins / 10 mins / 15 mins / 20 mins / 25 mins / 30 mins
		Sleep Timer	Disable / 30 mins / 1 hr / 2 hrs / 3 hrs / 4 hrs / 8 hrs / 12 hrs
		Reset Filter Timer	Reset / Cancel
	Remote Receiver	Front+Rear / Front / Rear	
	Background Color	BenQ / Black / Blue / Purple	
	Splash Screen	BenQ / Black / Blue	
	System Setup: Advanced	High Altitude Mode	On / Off
Audio Settings		Mute	On / Off
		Volume	
		Build-in speaker	On / Off
		Power on/off Ring	On / Off
Light Source Settings		Light Source Mode	Normal / Economic / Dimming / Custom
		Custom Brightness	25%-100%
		Reset Light Source Timer	Reset / Cancel
		Light Source Information	Light Source Usage Time / Normal Mode / Economic Mode / Dimming Mode / Custom Mode
Security Setting		Change Password	
		Change Security Settings	
		Power On Lock	On / Off
Baud Rate		2400 / 4800 / 9600 / 14400 / 19200 / 38400 / 57600 / 115200	

Main menu	Sub-menu	Options		
System Setup: Advanced	Test Pattern	Off/ Grid/ White/ Red/ Green/ Blue/ Black/ RGB Ramps/ Color Bar/ Step Bars/ CheckBoard/ Horizontal Lines/ Vertical Lines/ Diagonal Lines/ Horizontal Ramp/ Vertical Ramps		
	Projector ID Setting	Off/ 01~99		
	Closed Caption	Closed Caption Enable	On/ Off	
		Caption Version	CC1/ CC2/ CC3/ CC4	
	I2V Trigger	On/ Off		
	Standby Settings	Network	Enable Network Standby Mode Auto Disable Network Standby Mode	
			Monitor Out	On/ Off
		Audio Pass Through		Audio In/ Audio L/R/ HDMI 1/ HDMI 2/MHL/ Off
		Network settings	Wired LAN	Status DHCP IP Address Subnet Mask Default Gateway DNS Server Apply
	AMX Device Discovery			On/ Off
	Mac Address			
	Reset All Settings			Reset/ Cancel
	Information	Current System Status	<ul style="list-style-type: none"> • Source • Picture Mode • Lightsource Mode • Resolution • 3D Format • Color System • Lightsource Usage Time • Projector ID • Firmware Version 	

Maintenance

Before maintaining the projector

- Make sure to turn off the power before maintaining the projector.
- When switching off the projector, make sure to follow the procedures in "[Switch off the projector](#)" on page 40.

Care of the projector

Your projector needs little maintenance. The only thing you need to do on a regular basis is to keep the lens clean.

Never remove any parts of the projector. Contact your dealer if other parts need replacing.

Clean the lens front surface

Clean the lens whenever you notice dirt or dust on the surface.

- Use a canister of compressed air to remove dust.
- If there is dirt or smears, use lens-cleaning paper or moisten a soft cloth with lens cleaner and gently wipe the lens surface.



Caution:

Never use any type of abrasive pad, alkaline/acid cleaner, scouring powder, or volatile solvent, such as alcohol, benzene, thinner or insecticide. Using such materials or maintaining prolonged contact with rubber or vinyl materials may result in damage to the projector surface and cabinet material.

Clean the projector case

Before you clean the case, turn the projector off using the proper shutdown procedure as described in "[Switch off the projector](#)" on page 40 and unplug the power cord.

- To remove dirt or dust, wipe the case with a soft, lint-free cloth.
- To remove stubborn dirt or stains, moisten a soft cloth with water and a neutral pH detergent. Then wipe the case.



Caution:

Never use wax, alcohol, benzene, thinner or other chemical detergents. These can damage the case.

Filter maintenance

Cleaning the filter

The air filter prevents dust from accumulating on the surface of the optical elements inside the projector. If the filter is dirty or clogged, your projector may overheat or degrading the projected image quality.

1. Turn off the projector, and unplug the AC power cord from the AC outlet.
2. Cleaning the filter with a vacuum cleaner.



Caution:

Recommend avoiding dusty or smoky environments when you operate the projector; it may cause poor image quality. If the filter is heavily clogged and unable to clean, replace a new filter.

Note:

Using a ladder is recommended to access the filter. Do not remove the projector from the wall mount.

Replacing the side filter

1. Turn off the projector and unplug the power cord from the outlet. Remove any dust on the projector and around the air vents. Loosen the two captive screws that secure the filter cover.

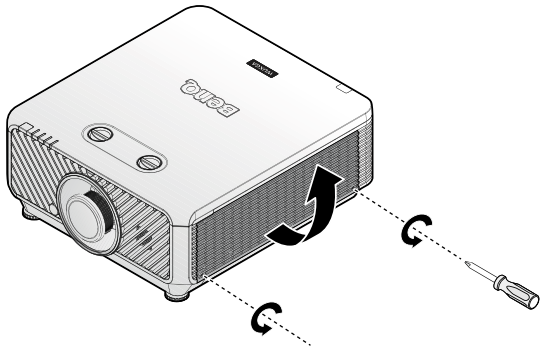

2. Flip up the filter cover.

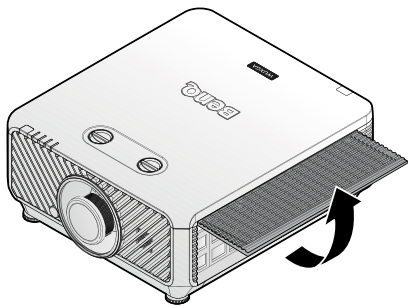

3. Remove the filter module from the projector.

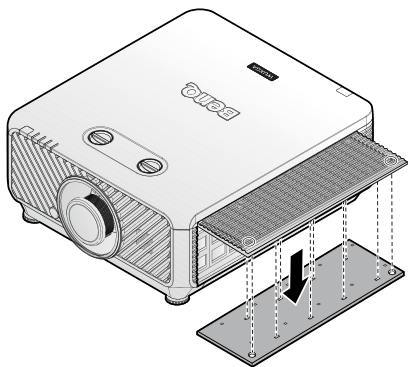

4. Align the holes on the new filter module with the captive screws on the filter cover.

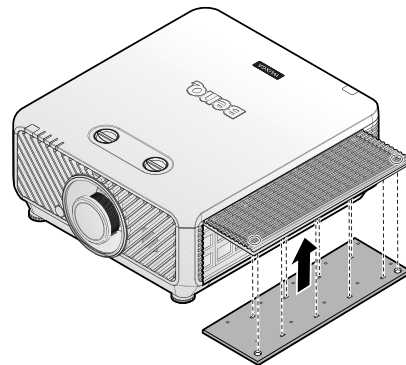

5. Replace the filter cover onto the projector by pushing gently in the direction shown and tighten the screws.

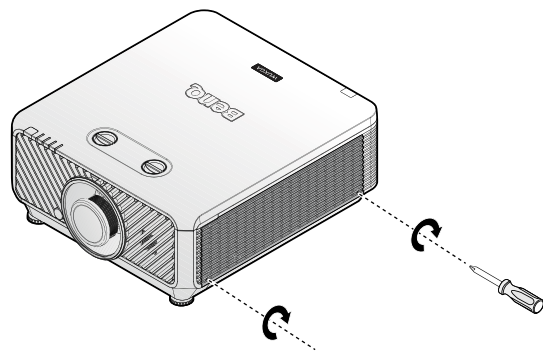

Replacing the front filter

1. Turn off the projector and unplug the power cord from the outlet. Remove any dust on the projector and around the air vents. Loosen the two captive screws that secure the filter cover.
4. Replace the filter cover into the projector by pushing gently in the direction shown.



2. Remove the filter module from the projector.



3. Replace the new filter module with the filter cover.

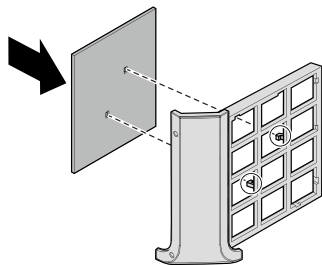

5. Tighten the screws.



Note:

Do not wash the filter with the water or other liquid matter.

Resetting the filter timer

6. After the startup logo, open the On-Screen Display (OSD) menu. Go to the **SYSTEM SETUP: Basic > Operation Settings** menu. Press **ENTER**. The Operation Settings page displays. Highlight **Reset Filter Timer**. A warning message displays asking if you want to reset the filter timer. Highlight **Reset** and press **ENTER**. The filter time will be reset to '0'.

LED indicator

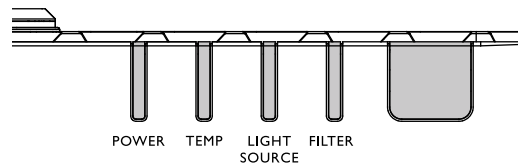

System message

Power	Temp	Light	Filter	Status & Description
Orange	-	-	-	Stand-by
Green Flashing	-	-	-	Powering up
Green	-	-	-	Normal operation
Orange Flashing	-	-	-	Normal power down cooling
Red	Red	Red	-	Downloading
Green	-	Red	-	Color wheel start fail
Green	-	Red Flashing	-	Phosphor wheel start fail
Red Flashing	-	-	-	Scaler shutdown fail
Red	-	Red	-	Scaler reset fail
-	Red	-	-	LAN download fail
-	Green	-	-	LAN download processing
Green	-	Orange	-	Lightsource life exhausted
-	Green	Red Flashing	-	Lens release
-	Green	Red	-	Case open

Light source error message

Power	Temp	Light	Filter	Status & Description
-	-	Red	-	Lightsource error in normal operation
--	-	Orange Flashing	Red	Lightsource is not lit up

Filter message

Power	Temp	Light	Filter	Status & Description
Green	-	-	Orange	Filter replace warning

Thermal error message

Power	Temp	Light	Filter	Status & Description
Red	Red	-	-	Fan 1 error
Red	Red Flashing	-	-	Fan 2 error
Red	Green	-	-	Fan 3 error
Red	Green Flashing	-	-	Fan 4 error
Red Flashing	Red	-	-	Fan 5 error
Red Flashing	Red Flashing	-	-	Fan 6 error
Red Flashing	Green	-	-	Fan 7 error
Red Flashing	Green Flashing	-	-	Fan 8 error
Red	Red	-	Green	Fan 9 error
Green	Red	-	-	Temperature 1 error
Green	Red Flashing	-	-	Thermal sensor 1 open error
Green	Green	-	-	Thermal sensor 1 short error
Green	Green Flashing	-	-	Thermal IC #1 I2C connection error
Green Flashing	Red	-	-	Temperature 2 error
Green Flashing	Red Flashing	-	-	Thermal sensor 2 open error
Green Flashing	Green	-	-	Thermal sensor 2 short error
Green Flashing	Green Flashing	-	-	Thermal IC #2 I2C connection error
Green Flashing	Green	Green	-	Temperature 3 error
Orange	Red Flashing	-	-	Thermal sensor 3 open error
Orange	Green	-	-	Thermal sensor 3 short error
Orange	Green Flashing	-	-	Thermal IC #3 I2C connection error
Green Flashing	Green	Green Flashing	-	Temperature 4 error
Green Flashing	Green Flashing	Green	-	Temperature 5 error
Green	Red	Red	-	Thermal break warning

Troubleshooting

Troubleshooting

The projector does not turn on.

Cause	Remedy
There is no power from the power cable.	Plug the power cord into the AC inlet on the projector, and plug the power cord into the power outlet. If the power outlet has a switch, make sure that it is switched on.
Attempting to turn the projector on again during the cooling process.	Wait until the cooling down process has completed.

No picture.

Cause	Remedy
The video source is not turned on or connected correctly.	Turn the video source on and check that the signal cable is connected correctly.
The projector is not correctly connected to the input signal device.	Check the connection.
The input signal has not been correctly selected.	Select the correct input signal with the SOURCE key on the projector or remote control.

Blurred image.

Cause	Remedy
The projection lens is not correctly focused.	Adjust the focus of the lens using the focus ring.
The projector and the screen are not aligned properly.	Adjust the projection angle and direction as well as the height of the unit if necessary.
The lens cover is still closed.	Open the lens cover.

Remote control does not work.

Cause	Remedy
The battery is out of power.	Replace the battery with new one.
There is an obstacle between the remote control and the projector.	Remove the obstacle.
You are too far away from the projector.	Stand within 7 meters (23 feet) of the projector.

The password is incorrect.

Cause	Remedy
You do not remember the password.	<ol style="list-style-type: none"> 1. Press and hold AUTO on the projector or remote control for 3 seconds. The projector will display a coded number on the screen. 2. Write down the number and turn off your projector. 3. Seek help from the local BenQ service center to decode the number. You may be required to provide proof of purchase documentation to verify that you are an authorized user of the projector.

Specifications

Specifications

Optical

Resolution

LX9215

1024 x 768

LU9235

1920 x 1200

Display system

Single-chip DLP™ system

Lens F/Number

STANDARD LS2SD2

F=2.0 to 2.09, f=22.84 to 28.61mm

WIDE FIX LS2ST3

F=2.54, f=11.46mm

WIDE ZOOM LS2ST1

F=2.5 to 3.1, f=28.5 to 42.75mm

SEMI LONG LS2LT1

F=2.05 to 2.27, f=16.64 to 19.5mm

LONG ZOOM1 LS2LT2

F=2.2 to 2.5, f=44.5 to 74.19mm

Light source

Laser diodes

Electrical

Power supply

AC100-240V

50/60 Hz (Automatic)

6.5A

Power consumption

650W (Max); < 0.5W (Standby)

Mechanical

Weight

52.8 lbs (24 Kg) (without lens)

Output terminals

Speaker

10 watt x 2 (peak to peak)

Audio signal output

RCA R/L jack x 1

Monitor Out

D-Sub 15-pin (female) x1

USB

TYPE-A (5V/1.5A)

3D SYNC OUT x 1

Wire Remote

PC audio jack x 1

Control

USB

Type-B x1

RS-232 serial control

9 pin x 1

IR receiver x 2

12V TRIGGER

12VDC (Max. 0.2 A) x 1

LAN control

RJ45 x 1

Wired Remote

PC audio jack x 1

Input terminals

Computer input

RGB input

D-Sub 15-pin (female) x 1

BNC x 5

Digital input

DVI-D x 1

Video signal input

COMPONENT

D-Sub 15-pin (female) x 1

BNC x 3

VIDEO

RCA jack x 1

SD/HDTV signal input

Digital - HDMI x 1

HDMI 2/MHL x 1

RJ45 x1 (HDBaseT)

Audio signal input

Audio in

PC audio jack x 1

RCA audio jack (L/R) x 1

Environmental Requirements

Operating temperature

0°C–40°C at sea level

Operating relative humidity

10%–90% (without condensation)

Operating altitude

0–1499 m at 0°C–35°C

1500–3000 m at 0°C–30°C (with High

Altitude Mode on)



Note:

All specifications are subject to change without notice.

Dimensions

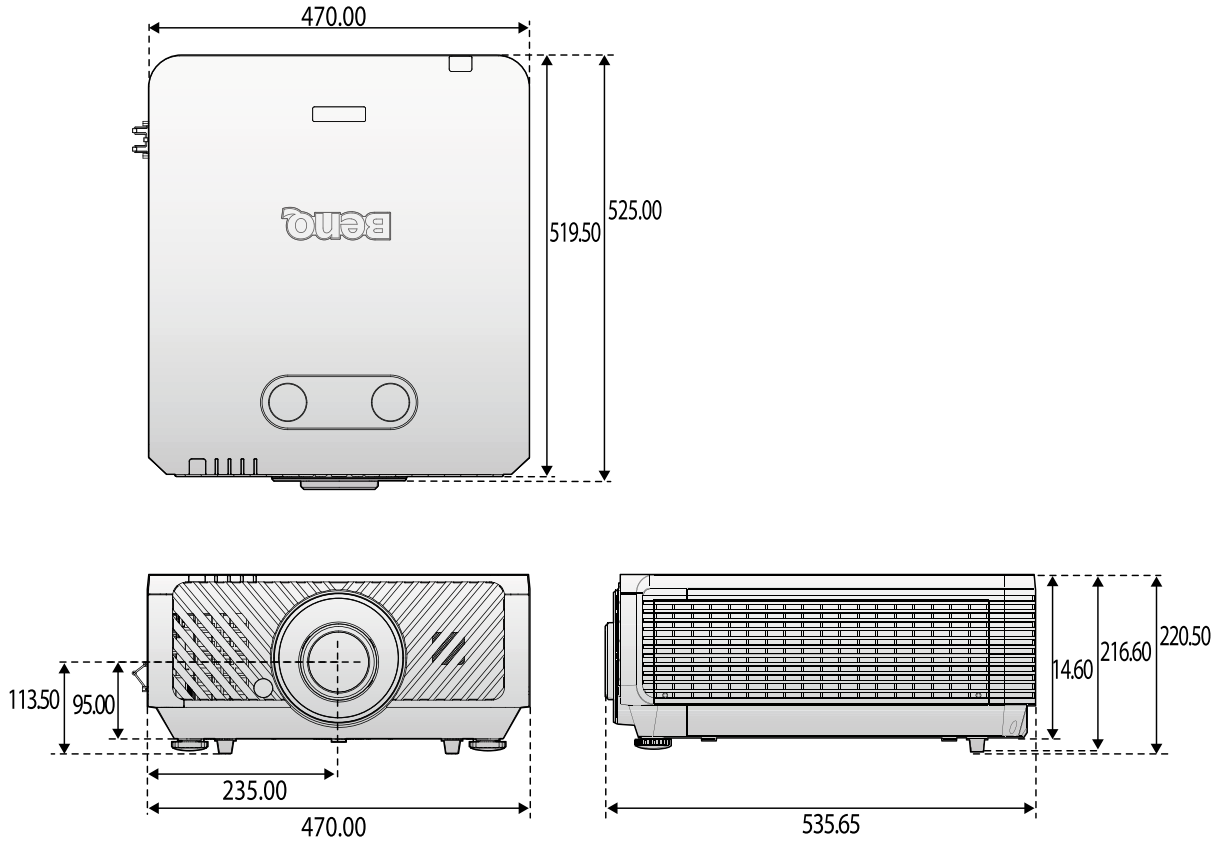

Attaching for ceiling mount

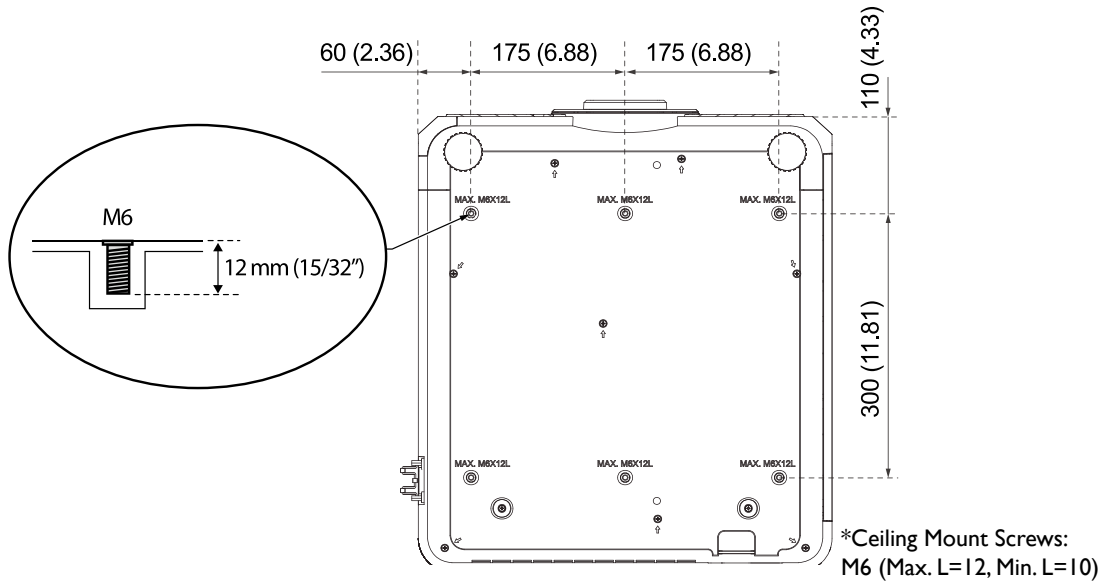

Appendix

Timing table

Supported timing for PC & PC 2 input

Resolution	Mode	Refresh Rate (Hz)	H Frequency (kHz)	Clock (MHz)	3D Frame Sequential	3D Top Bottom	3D side-by-side
720 x 400	720 x 400_70	70.087	31.469	28.3221			
640 x 480	VGA_60	59.940	31.469	25.175	⊙	⊙	⊙
	VGA_72	72.809	37.861	31.500			
	VGA_75	75.000	37.500	31.500			
	VGA_85	85.008	43.269	36.000			
800 x 600	SVGA_60	60.317	37.879	40.000	⊙	⊙	⊙
	SVGA_72	72.188	48.077	50.000			
	SVGA_75	75.000	46.875	49.500			
	SVGA_85	85.061	53.674	56.250			
	SVGA_120 (Reduce Blanking)	119.854	77.425	83.000	⊙		
1024 x 768	XGA_60	60.004	48.363	65.000	⊙	⊙	⊙
	XGA_70	70.069	56.476	75.000			
	XGA_75	75.029	60.023	78.750			
	XGA_85	84.997	68.667	94.500			
	XGA_120 (Reduce Blanking)	119.989	97.551	115.500	⊙		
1152 x 864	1152 x 864_75	75.000	67.500	108.000			
1024 x 576	BenQ NB Timing	60.000	35.820	46.996			
1024 x 600	BenQ NB Timing	64.995	41.467	51.419			
1280 x 720	1280 x 720_60	60.000	45.000	74.250	⊙	⊙	⊙
1280 x 768	1280 x 768_60	59.870	47.776	79.500	⊙	⊙	⊙
1280 x 800	WXGA_60	59.810	49.702	83.500	⊙	⊙	⊙
	WXGA_75	74.934	62.795	106.500			
	WXGA_85	84.880	71.554	122.500			
	WXGA_120 (Reduce Blanking)	119.909	101.563	146.250	⊙		
1280 x 1024	SXGA_60	60.020	63.981	108.000		⊙	⊙
	SXGA_75	75.025	79.976	135.000			
	SXGA_85	85.024	91.146	157.500			
1280 x 960	1280 x 960_60	60.000	60.000	108		⊙	⊙
	1280 x 960_85	85.002	85.938	148.500			
1360 x 768	1360 x 768_60	60.015	47.712	85.500		⊙	⊙

Resolution	Mode	Refresh Rate (Hz)	H Frequency (kHz)	Clock (MHz)	3D Frame Sequential	3D Top Bottom	3D side-by-side
1440 x 900	WXGA+_60	59.887	55.935	106.500		⊙	⊙
1400 x 1050	SXGA+_60	59.978	65.317	121.750		⊙	⊙
1600 x 1200	UXGA	60.000	75.000	162.000		⊙	⊙
1680 x 1050	1680 x 1050_60	59.954	65.290	146.250		⊙	⊙
*1920 x 1080 @60Hz	1920 x 1080_60 (Reduce Blanking)	60.000	67.500	148.500			
*1920 x 1200 @60Hz	1920 x 1200_60 (Reduce Blanking)	59.950	74.038	154.000			
640 x 480 @67Hz	MAC13	66.667	35.000	30.240			
832 x 624 @75Hz	MAC16	74.546	49.722	57.280			
1024 x 768 @75Hz	MAC19	74.930	60.241	80.000			
1152 x 870 @75Hz	MAC21	75.060	68.68	100.000			

Note:

There 3D timing showing depend the EDID file and VGA display card. It is possible that user cannot choose the above 3D timings on VGA display card.

*: No available in PC 2.

Support timing for Component - YPbPr input

Timing	Resolution	Horizontal Frequency (KHz)	Vertical Frequency (Hz)	Dot Clock Frequency (MHz)	3D Frame Sequential
480i	720 x 480	15.73	59.94	13.50	⊙
480p	720 x 480	31.47	59.94	27.00	⊙
576i	720 x 576	15.63	50.00	13.50	
576p	720 x 576	31.25	50.00	27.00	
720/50p	1280 x 720	37.50	50.00	74.25	
720/60p	1280 x 720	45.00	60.00	74.25	⊙
1080/50i	1920 x 1080	28.13	50.00	74.25	
1080/60i	1920 x 1080	33.75	60.00	74.25	
1080/24p	1920 x 1080	27.00	24.00	74.25	
1080/25p	1920 x 1080	28.13	25.00	74.25	
1080/30p	1920 x 1080	33.75	30.00	74.25	
1080/50p	1920 x 1080	56.25	50.00	148.50	
1080/60p	1920 x 1080	67.50	60.00	148.50	

Support timing for Video input

Video Mode	Horizontal Frequency (KHz)	Vertical Frequency (Hz)	Sub-carrier Frequency (MHz)	3D Frame Sequential
NTSC	15.73	60	3.58	⊙
PAL	15.63	50	4.43	
SECAM	15.63	50	4.25 or 4.41	
PAL-M	15.73	60	3.58	
PAL-N	15.63	50	3.58	
PAL-60	15.73	60	4.43	
NTSC4.43	15.73	60	4.43	

Support timing for HDMI & DVI-D (HDCP) input

Resolution	Mode	Refresh Rate (Hz)	H Frequency (kHz)	Clock (MHz)	3D Frame Sequential	3D Top Bottom	3D side-by-side
640 x 480	VGA_60	59.940	31.469	25.175	⊙	⊙	⊙
	VGA_72	72.809	37.861	31.500			
	VGA_75	75.000	37.500	31.500			
	VGA_85	85.008	43.269	36.000			
720 x 400	720 x 400_70	70.087	31.469	28.3221			
800 x 600	SVGA_60	60.317	37.879	40.000	⊙	⊙	⊙
	SVGA_72	72.188	48.077	50.000			
	SVGA_75	75.000	46.875	49.500			
	SVGA_85	85.061	53.674	56.250			
	SVGA_120 (Reduce Blanking)	119.854	77.425	83.000	⊙		
1024 x 768	XGA_60	60.004	48.363	65.000	⊙	⊙	⊙
	XGA_70	70.069	56.476	75.000			
	XGA_75	75.029	60.023	78.750			
	XGA_85	84.997	68.667	94.500			
	XGA_120 (Reduce Blanking)	119.989	97.551	115.500	⊙		
1152 x 864	1152 x 864_75	75.000	67.500	108.000			
1024 x 576	BenQ Notebook Timing	60.000	35.820	46.996			
1024 x 600	BenQ Notebook Timing	64.995	41.467	51.419			
1280 x 720	1280 x 720_60	60.000	45.000	74.250	⊙	⊙	⊙
1280 x 768	1280 x 768_60	59.870	47.776	79.5	⊙	⊙	⊙

Resolution	Mode	Refresh Rate (Hz)	H Frequency (kHz)	Clock (MHz)	3D Frame Sequential	3D Top Bottom	3D side-by-side
1280 x 800	WXGA_60	59.810	49.702	83.500	⊙	⊙	⊙
	WXGA_75	74.934	62.795	106.500			
	WXGA_85	84.880	71.554	122.500			
	WXGA_120 (Reduce Blanking)	119.909	101.563	146.250	⊙		
1280 x 1024	SXGA_60	60.020	63.981	108.000		⊙	⊙
	SXGA_75	75.025	79.976	135.000			
	SXGA_85	85.024	91.146	157.500			
1280 x 960	1280 x 960_60	60.000	60.000	108.000		⊙	⊙
	1280 x 960_85	85.002	85.938	148.500			
1360 x 768	1360 x 768_60	60.015	47.712	85.500		⊙	⊙
1440 x 900	WXGA+_60	59.887	55.935	106.500		⊙	⊙
1400 x 1050	SXGA+_60	59.978	65.317	121.750		⊙	⊙
1600 x 1200	UXGA	60.000	75.000	162.000		⊙	
1680 x 1050	1680 x 1050_60	59.954	65.290	146.250		⊙	⊙
1920 x 1080 @60Hz	1920 x 1080_60 (Reduce Blanking)	60.000	67.500	148.500			
1920 x 1200 @60Hz	1920 x 1200_60 (Reduce Blanking)	59.950	74.038	154.000			
640 x 480 @67Hz	MAC13	66.667	35.000	30.240			
832 x 624 @75Hz	MAC16	74.546	49.722	57.280			
1024 x 768 @75Hz	MAC19	75.020	60.241	80.000			
1152 x 870 @75Hz	MAC21	75.060	68.680	100.000			

 **Note:**

There timing showing depend the EDID file and VGA graphic card limitation. It is possible that user cannot choose the above timings on VGA display card.

Supporting timing for HDMI Video input

Timing	Resolution	Horizontal Frequency (KHz)	Vertical Frequency (Hz)	Dot Clock Frequency (MHz)	3D Frame Sequential	3D Frame Packing	3D Top Bottom	3D side-by-side
480i	720 (1440) x 480	15.73	59.94	27.00	⊙			
480p	720 x 480	31.47	59.94	27.00	⊙			
576i	720 (1440) x 576	15.63	50.00	27.00				
576p	720 x 576	31.25	50.00	27.00				
720/50p	1280 x 720	37.50	50.00	74.25		⊙	⊙	⊙
720/60p	1280 x 720	45.00	60.00	74.25	⊙	⊙	⊙	⊙
1080/24p	1920 x 1080	27.00	24.00	74.25		⊙	⊙	⊙
1080/25p	1920 x 1080	28.13	25.00	74.25				
1080/30p	1920 x 1080	33.75	30.00	74.25				
1080/50i	1920 x 1080	28.13	50.00	74.25				⊙
1080/60i	1920 x 1080	33.75	60.00	74.25				⊙
1080/50p	1920 x 1080	56.25	50.00	148.50			⊙	⊙
1080/60p	1920 x 1080	67.50	60.00	148.50			⊙	⊙

RS232 command control

Function	Type	Operation	ASCII
Power	Write	Power On	<CR>*pow=on#<CR>
	Write	Power off	<CR>*pow=off#<CR>
	Read	Power Status	<CR>*pow=?#<CR>
Source Selection	Write	COMPUTER/YPbPr	<CR>*sour=RGB#<CR>
	Write	COMPUTER 2/YPbPr2	<CR>*sour=RGB2#<CR>
	Write	DVI-D	<CR>*sour=dvid#<CR>
	Write	HDMI	<CR>*sour=hdmi#<CR>
	Write	HDMI 2/MHL2	<CR>*sour=hdmi2#<CR>
	Write	Composite	<CR>*sour=vid#<CR>
	Write	HDbaseT	<CR>*sour=hdbaset#<CR>
	Read	Current source	<CR>*sour=?#<CR>
Audio Control	Write	Mute On	<CR>*mute=on#<CR>
	Write	Mute Off	<CR>*mute=off#<CR>
	Read	Mute Status	<CR>*mute=?#<CR>
	Write	Volume +	<CR>*vol=+#<CR>
	Write	Volume -	<CR>*vol=-#<CR>
	Read	Volume Status	<CR>*vol=?#<CR>
Audio source select	Write	Audio pass Through off	<CR>*audiosour=off#<CR>
	Write	Audio-Computer1	<CR>*audiosour=RGB#<CR>
	Write	Audio-Computer2	<CR>*audiosour=RGB2#<CR>
	Write	Audio-Video	<CR>*audiosour=vid#<CR>
	Write	Audio-Component	<CR>*audiosour=ypbr#<CR>
	Write	Audio-HDMI	<CR>*audiosour=hdmi#<CR>
	Write	Audio-HDMI2	<CR>*audiosour=hdmi2#<CR>
	Read	Audio pass Status	<CR>*audiosour=?#<CR>
Picture Mode	Write	Presentation	<CR>*appmod=preset#<CR>
	Write	sRGB	<CR>*appmod=srgb#<CR>
	Write	Bright	<CR>*appmod=bright#<CR>
	Write	Cinema	<CR>*appmod=cine#<CR>
	Write	DICOM	<CR>*appmod=dicom#<CR>
	Write	User1	<CR>*appmod=user1#<CR>
	Write	3D	<CR>*appmod=threed#<CR>
	Read	Picture Mode	<CR>*appmod=?#<CR>

Function	Type	Operation	ASCII
Picture Setting	Write	Contrast +	<CR>*con=+#<CR>
	Write	Contrast -	<CR>*con=-#<CR>
	Read	Contrast value	<CR>*con=?#<CR>
	Write	Brightness +	<CR>*bri=+#<CR>
	Write	Brightness -	<CR>*bri=-#<CR>
	Read	Brightness value	<CR>*bri=?#<CR>
	Write	Color +	<CR>*color=+#<CR>
	Write	Color -	<CR>*color=-#<CR>
	Read	Color value	<CR>*color=?#<CR>
	Write	Sharpness +	<CR>*sharp=+#<CR>
	Write	Sharpness -	<CR>*sharp=-#<CR>
	Read	Sharpness value	<CR>*sharp=?#<CR>
	Write	Color Temperature-Warm	<CR>*ct=warm#<CR>
	Write	Color Temperature-Normal	<CR>*ct=normal#<CR>
	Write	Color Temperature-Cool	<CR>*ct=cool#<CR>
	Read	Color Temperature Status	<CR>*ct=?#<CR>
	Write	Aspect 4:3	<CR>*asp=4:3#<CR>
	Write	Aspect 16:9	<CR>*asp=16:9#<CR>
	Write	Aspect 16:10	<CR>*asp=16:10#<CR>
	Write	Aspect Auto	<CR>*asp=AUTO#<CR>
	Write	Aspect Real	<CR>*asp=REAL#<CR>
	Read	Aspect Status	<CR>*asp=?#<CR>
	Write	Digital Zoom In	<CR>*zoomI#<CR>
	Write	Digital Zoom out	<CR>*zoomO#<CR>
	Write	Auto	<CR>*auto#<CR>
	Write	Brilliant color on	<CR>*BC=on#<CR>
Write	Brilliant color off	<CR>*BC=off#<CR>	
Read	Brilliant color status	<CR>*BC=?#<CR>	
Operation Settings	Write	Projector Position-Front Table	<CR>*pp=FT#<CR>
	Write	Projector Position-Rear Table	<CR>*pp=RE#<CR>
	Write	Projector Position-Rear Ceiling	<CR>*pp=RC#<CR>
	Write	Projector Position-Front Ceiling	<CR>*pp=FC#<CR>
	Write	Quick auto search	<CR>*QAS=on#<CR>
	Write	Quick auto search	<CR>*QAS=off#<CR>
	Read	Quick auto search status	<CR>*QAS=?#<CR>
	Read	Projector Position Status	<CR>*pp=?#<CR>
	Write	Direct Power On-on	<CR>*directpower=on#<CR>

Function	Type	Operation	ASCII
Operation Settings	Write	Direct Power On-off	<CR>*directpower=off#<CR>
	Read	Direct Power On-Status	<CR>*directpower=?#<CR>
	Write	Signal Power On-on	<CR>*autopower=on#<CR>
	Write	Signal Power On-off	<CR>*autopower=off#<CR>
	Read	Signal Power On-Status	<CR>*autopower=?#<CR>
	Write	Standby Settings-Network on	<CR>*standbynet=on#<CR>
	Write	Standby Settings-Network off	<CR>*standbynet=off#<CR>
	Read	Standby Settings-Network Status	<CR>*standbynet=?#<CR>
	Write	Standby Settings-Monitor Out on	<CR>*standbymnt=on#<CR>
	Write	Standby Settings-Monitor Out off	<CR>*standbymnt=off#<CR>
	Read	Standby Settings-Monitor Out Status	<CR>*standbymnt=?#<CR>
Baud Rate	Write	2400	<CR>*baud=2400#<CR>
	Write	4800	<CR>*baud=4800#<CR>
	Write	9600	<CR>*baud=9600#<CR>
	Write	14400	<CR>*baud=14400#<CR>
	Write	19200	<CR>*baud=19200#<CR>
	Write	38400	<CR>*baud=38400#<CR>
	Write	57600	<CR>*baud=57600#<CR>
	Write	115200	<CR>*baud=115200#<CR>
	Read	Current Baud Rate	<CR>*baud=?#<CR>
Lamp Control	Read	Lamp Hour	<CR>*ltim=?#<CR>
	Write	Normal mode	<CR>*lampm=lnor#<CR>
	Write	Eco mode	<CR>*lampm=eco#<CR>
	Write	Dimming mode	<CR>* lampm=dimming#<CR>
	Write	Custom mode	<CR>* lampm=custom#<CR>
	Read	Lamp Mode Status	<CR>*lampm=?#<CR>
Miscellaneous	Read	Model Name	<CR>*modelName=?#<CR>
	Write	Blank On	<CR>*blank=on#<CR>
	Write	Blank Off	<CR>*blank=off#<CR>
	Read	Blank Status	<CR>*blank=?#<CR>
	Write	Freeze On	<CR>*freeze=on#<CR>
	Write	Freeze Off	<CR>*freeze=off#<CR>
	Read	Freeze Status	<CR>*freeze=?#<CR>
	Write	Menu On	<CR>*menu=on#<CR>
	Write	Menu Off	<CR>*menu=off#<CR>
	Write	Up	<CR>*up#<CR>
	Write	Down	<CR>*down#<CR>

Function	Type	Operation	ASCII
Miscellaneous	Write	Right	<CR>*right#<CR>
	Write	Left	<CR>*left#<CR>
	Write	Enter	<CR>*enter#<CR>
	Write	3D Sync Off	<CR>*3d=off#<CR>
	Write	3D Auto	<CR>*3d=auto#<CR>
	Write	3D Sync Top Bottom	<CR>*3d=tb#<CR>
	Write	3D Sync Frame Sequential	<CR>*3d=fs#<CR>
	Write	3D Frame packing	<CR>*3d=fp#<CR>
	Write	3D Side by side	<CR>*3d=sbs#<CR>
	Write	3D inverter disable	<CR>*3d=da#<CR>
	Write	3D inverter	<CR>*3d=iv#<CR>
	Read	3D Sync Status	<CR>*3d=?#<CR>
	Write	Remote Receiver-front+rear	<CR>*rr=fr#<CR>
	Write	Remote Receiver-front	<CR>*rr=f#<CR>
	Write	Remote Receiver-rear	<CR>*rr=r#<CR>
	Read	Remote Receiver Status	<CR>*rr=?#<CR>
	Write	AMX Device Discovery-on	<CR>*amxdd=on#<CR>
	Write	AMX Device Discovery-off	<CR>*amxdd=off#<CR>
	Read	AMX Device Discovery Status	<CR>*amxdd=?#<CR>
	Read	Mac Address	<CR>*macaddr=?#<CR>
	Write	High Altitude mode on	<CR>*Highaltitude=on#<CR>
Write	High Altitude mode off	<CR>*Highaltitude=off#<CR>	
Read	High Altitude mode status	<CR>*Highaltitude=?#<CR>	

PJLink

PJLink protocol

The network function of this projector support the PJLink class I, and the PJLink protocol can be used to perform projector setting and projector status query operations from a computer.

Control commands

The following table lists the PJLink protocol commands that can be used to control the projector.

- x characters in table are non-specific characters.

Command	Control Details	Parameter/ Return String	Remark		
POWR	Power supply control	0	Standby		
		1	Power on		
POWR?	Power supply status query	0	Standby		
		1	Power on		
INPT	Input selection	11	PC1 / YPbPr1		
INPT?	Input status query	12	PC2 / YPbPr2		
		21	VIDEO		
		31	HDMI1		
		32	HDMI2/MHL		
		33	DVI-D		
		34	HDBaseT		
AVMT	Mute	11	Video mute On		
AVMT?	Mute query	10	Video mute Off		
		21	Audio mute On		
		20	Audio mute Off		
		31	Video & Audio mute On		
		30	Video & Audio mute Off		
ERST?	Error status query	xxxxxx	1st byte	Indicates fan errors, and returns 0 - 2	<ul style="list-style-type: none"> • 0=No error is detected • 1=Warning • 2=Error
			2nd byte	Indicates light source errors, and returns 0 - 2	
			3rd byte	Indicates temperature errors, and returns 0 - 2	
			4th byte	Return 0	
			5th byte	Return 0	
			6th byte	Indicates other errors, and returns 0 - 2	
LAMP?	Light source status query	xxxxxxxxxxxx	1st number (1-5 digitals): Light source 1 runtime		
INST?	Input selection list query	11 12 21 31 32 33 34	LU9235 / LX9215		

Command	Control Details	Parameter/ Return String	Remark
NAME?	Projector name query	xxxxx	Returns the name set in [PROJECTOR NAME] of [NETWORK SETUP]
INF1?	Manufacturer name query	BenQ	Returns manufacturer name
INF2?	Model name query	LU9235 / LX9215	Returns model name
INF0?	Other information queries	xxxxx	Returns information such as version number
CLASS?	Class information query	I	Returns class for PJLink