



Hall Technologies • 1234 Lakeshore Dr Suite #150 Coppell, TX 75019 • halltechav.com

HT-RANGER

BYOD Presentation Switcher

USER MANUAL

January 19, 2023



Important Safety Instructions



1. Do not expose this apparatus to rain, moisture, dripping or splashing and that no objects filled with liquids, such as vases, shall be placed on the apparatus.



2. Do not install or place this unit in a bookcase, built-in cabinet or in another confined space. Ensure the unit is well ventilated.



3. To prevent risk of electric shock or fire hazard due to overheating, do not obstruct the unit's ventilation openings with newspapers, tablecloths, curtains, and similar items.



4. Do not install near any heat sources such as radiators, heat registers, stoves, or other apparatus (including amplifiers) that produce heat.



5. Do not place sources of naked flames, such as lighted candles, on the unit.



6. Clean this apparatus only with dry cloth.

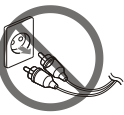

7. Unplug this apparatus during lightning storms or when unused for long periods of time.



8. Protect the power cord from being walked on or pinched particularly at plugs.



9. Only use attachments / accessories specified by the manufacturer.

10. Refer all servicing to qualified service personnel.

Table of Contents

Introduction.....	4
Overview	4
Features.....	4
Package Contents	4
Panel Description.....	5
Front Panel	5
Rear Panel.....	6
Installation and Wiring	7
Installation.....	7
Wiring.....	8
Key Functions	8
Screen Mirroring.....	8
(1) Screen Mirroring over Airplay (for Apple Devices)	9
(2) Screen Mirroring over Smart View (for Android Phones & Windows PCs)	10
(3) Screen Mirroring over Miracast (for Android Phones & Windows PCs)	10
(4) Screen Mirroring over HT-Voyager (HT Wireless Dongle)	12
Dual View Display	13
Automatic Signal Switching	13
Guide Screen	14
OSD.....	14
Web GUI	16
General Tab	18
Device Name.....	18
Wired Network	18
BYOD.....	19
Soft AP	20
Output	21
Display Control	22
Wi-Fi Settings.....	23
Password.....	23
Guide Screen	24
Maintenance.....	24
Version Info.....	25
Video Source Tab	25
State and Switch	25
Manage Alias	26
Firmware Upgrade.....	27
Troubleshooting	28
Specifications.....	29

Introduction

OVERVIEW

The HT-RANGER is a high-performance BYOD presentation switcher with wireless presentation capability. It includes a built-in Wi-Fi module and offers multiple connection options, including AirPlay, Miracast, Smart View, HT-Voyager and physical HDMI and USB-C ports. Connecting to the HT-RANGER using any of these methods can project the video from the connected device to the connected display, in either full screen mode or dual view mode.

The HT-RANGER includes multiple features such as automatic signal switching, CEC, Guide Screen, and OSD display.

FEATURES

- Dual view presentation.
- Built-in Wi-Fi module for wireless connectivity with devices over AirPlay, Miracast, Smart View, and HT-Voyager.
- Supports HDMI input and output resolutions up to 4K@30Hz 4:4:4.
- Detailed On Screen Display (OSD) information.
- Device control using Web UI and Telnet API.
- Laptops connected to the HT-RANGER using the USB-C interface can access USB peripheral devices (i.e. cameras, microphones) connected to USB-A ports on the HT-RANGER.

Package Contents

- 1 x Switcher
- 2 x Wi-Fi Antennas
- 1 x DC 12V Power Adapter with US Pins
- 2 x Mounting Brackets (with Screws)

Panel Description

FRONT PANEL



No.	Name	Description
1	Power LED	Solid yellow LED when the HT-RANGER is powered on.
2	Status LED	<ul style="list-style-type: none"> Solid yellow LED: The HT-RANGER is outputting at least one video source. Blinking yellow LED: The HT-RANGER is in standby mode Off: The HT-RANGER is displaying the Guide Screen.
3	Input Source LEDs	<ul style="list-style-type: none"> Solid yellow LED: The corresponding video input source signal is connected and is being displayed. Fast blinking yellow LED: The corresponding video input source signal is connected but the source is not being displayed. Slow blinking yellow LED: The corresponding video input source signal is being output but the signal is not valid. Off: The switcher is in standby mode, or the corresponding video input source signal is not connected.
4	Pairing	USB-C port for connecting to HT-Voyager for pairing.
5	Reset	<p>Reset button.</p> <p>When the switcher is powered on, use a pointed stylus to hold down this button for five or more seconds and then release. The HT-RANGER will reboot and restore to its factory defaults.</p>

REAR PANEL

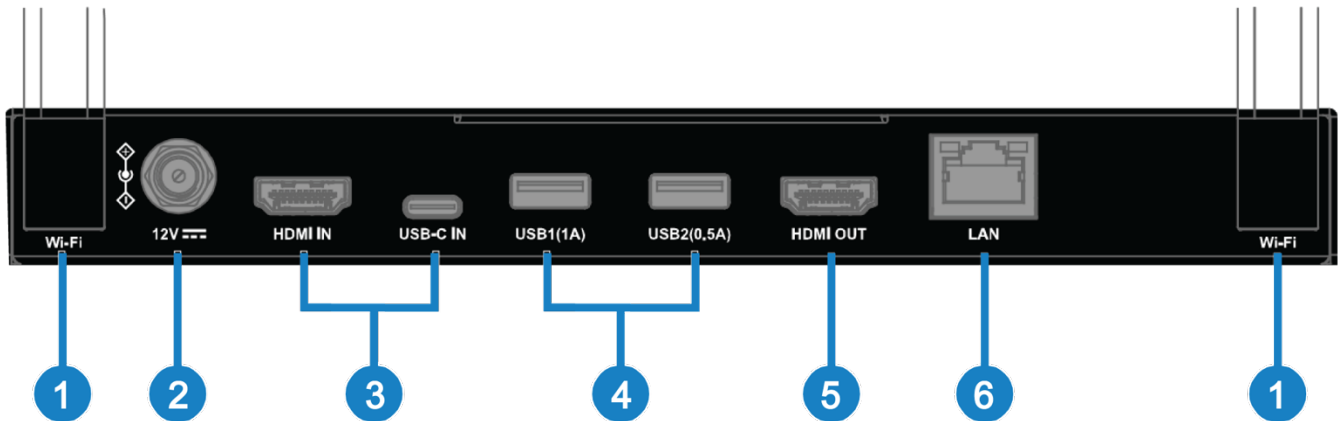

No.	Name	Description
1	Wi-Fi	Connect to the antenna pair provided for access to Miracast and the soft AP function.
2	12V	Connect to the DC 12V power adapter provided.
3	Input port	Connect to an HDMI and/or a USB-C source.
4	USB 1-2	<p>USB-A ports, supports the two following functions:</p> <p>(1) Connect to USB peripheral devices (e.g. keyboard, mouse, touch screen, etc.).</p> <p>Note: Both USB ports can supply power to the USB peripheral devices:</p> <ul style="list-style-type: none"> • USB1 port: outputs DC 5V 1A power • USB2 port: outputs DC 5V 0.5A power <p>(2) Connect either port to a U-disk for firmware upgrade. For more information, see Firmware Upgrade section.</p>
5	HDMI OUT	Connect to an HDMI display.
6	LAN	Connect to a network device (e.g. network switch, router, computer, etc.) for LAN control (Web GUI & Telnet API) and AirPlay mirroring signal input.

Installation and Wiring

INSTALLATION

Note: Before installation, please ensure the device is disconnected from the power source.

Attaching Antennas

1. Attach the included antenna to the threaded connector and screw it in clockwise.

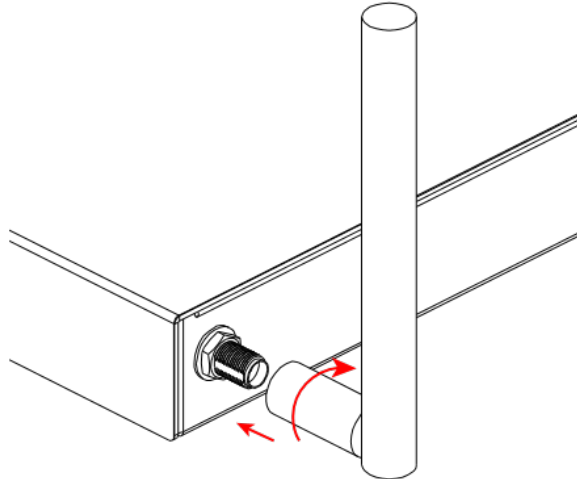

2. Repeat the above step for the other antenna.

Attaching Installation Brackets

1. Attach the included installation bracket to the enclosure using the screws provided.

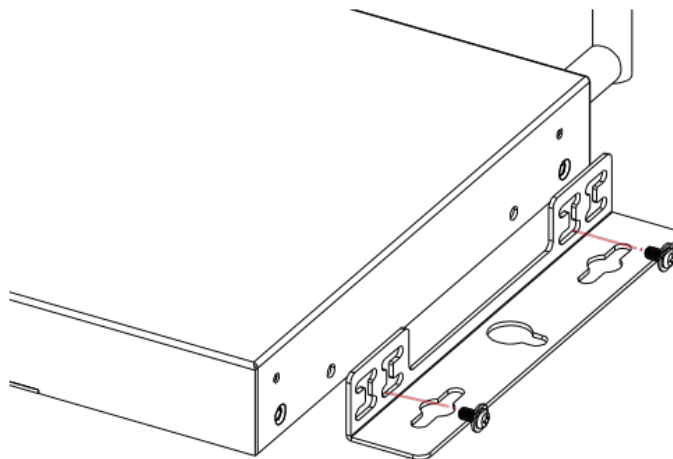

2. Repeat the step for the other side of the device.
3. Attach the brackets to the desired install surface (installation hardware not included).

WIRING

Warnings:

- Before wiring, ensure all devices are disconnected from power.
- When wiring, carefully connect and disconnect the cables, ensuring each connector is properly seated.

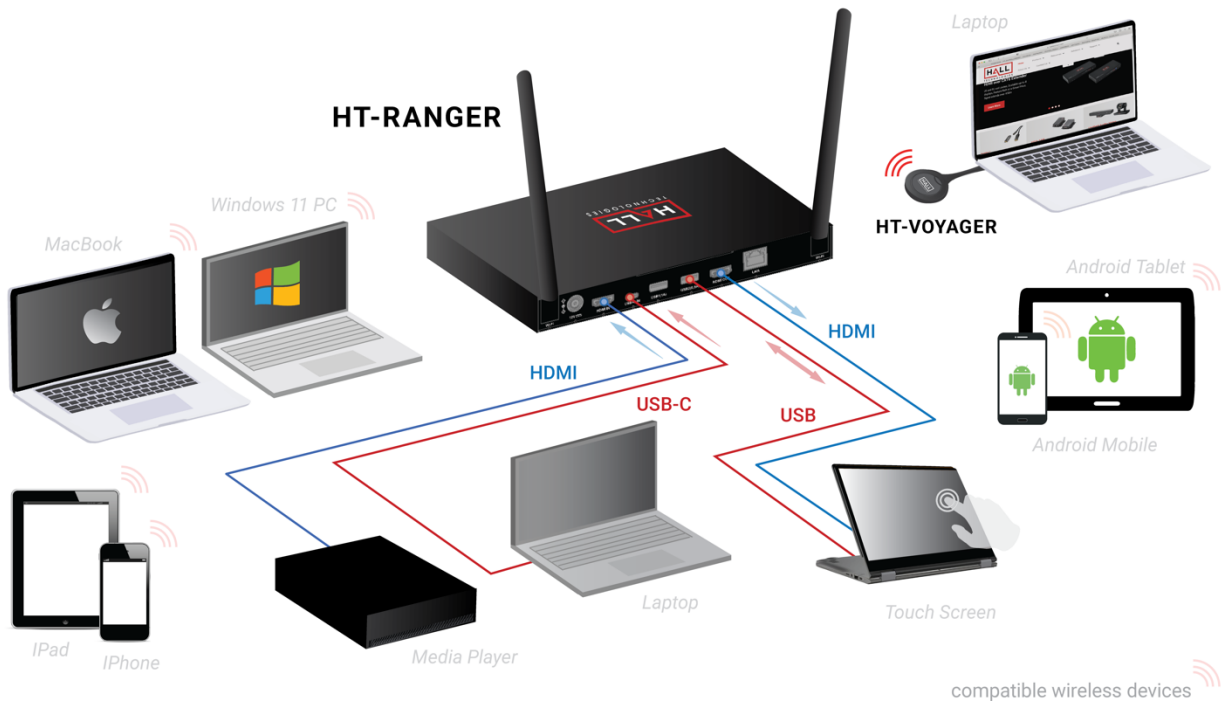

Note: By default, if the USB-C video source is displayed in full screen, all USB devices (i.e. cameras and microphones) connected to the USB Type-A ports of the switcher will be routed to the USB-C input port. This allows the laptop connected to the USB-C input access to these USB devices as if they were connected to the laptop directly.

Key Functions

The switcher supports multiple functions such as screen mirroring, dual view display, automatic signal switching, Guide Screen and OSD, providing simple use of the system.

SCREEN MIRRORING

With screen mirroring support, the HT-RANGER allows you to share your mobile devices' content wirelessly over AirPlay Mirroring, Miracast, Smart View, and HT-Voyager. In this manual, mobile devices available for screen mirroring are referred to as "screen mirroring sources", which include Apple devices (iPhone/iPad/Mac), Android phones, Windows PCs, and HT-VOYAGER.

1. Screen mirroring over airplay

Using an iPhone 8 (iOS 15.2) for example:

1. Connect your iPhone to the soft AP of the device.
 - ⇒ **Soft AP SSID:** this should be the same as the device name which can be obtained from the OSD at the upper right corner of the display screen. By default, it is set as **HT-RANGER**.
 - ⇒ **Password:** this password can be set through Web UI or Telnet API and can be obtained from the OSD at the bottom right corner of the display screen. By default, it is set as **12345678**.
2. Slide up from the bottom of the iPhone's screen to show the control center. Click **Screen Mirroring** and choose the device name in the pop-up list.

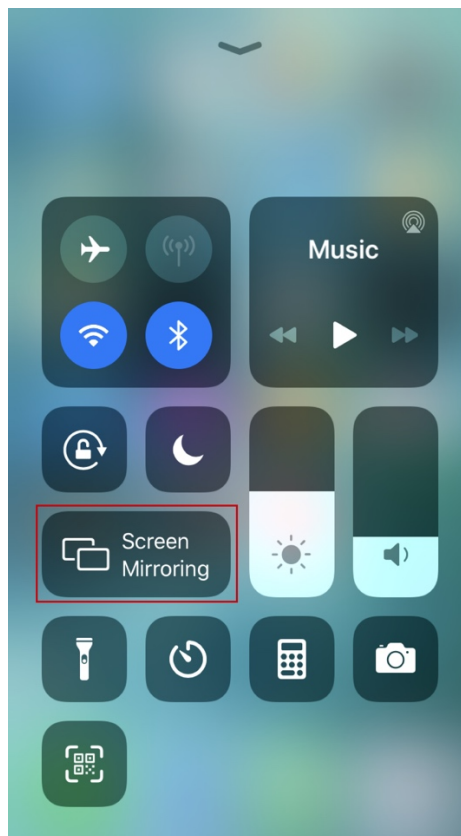

3. HT-RANGER now displays your iPhone's screen.
4. To disconnect iPhone from the device: click "Stop Mirroring". The display stops displaying your iPhone's screen.

2. Screen mirroring over Smart View

For Android mobile (using Samsung Galaxy S9 for example):

1. Enable the Wi-Fi or WLAN feature of the mobile.
2. Slide down from the top of the screen and click the **Smart View** icon in the pop-up interface.

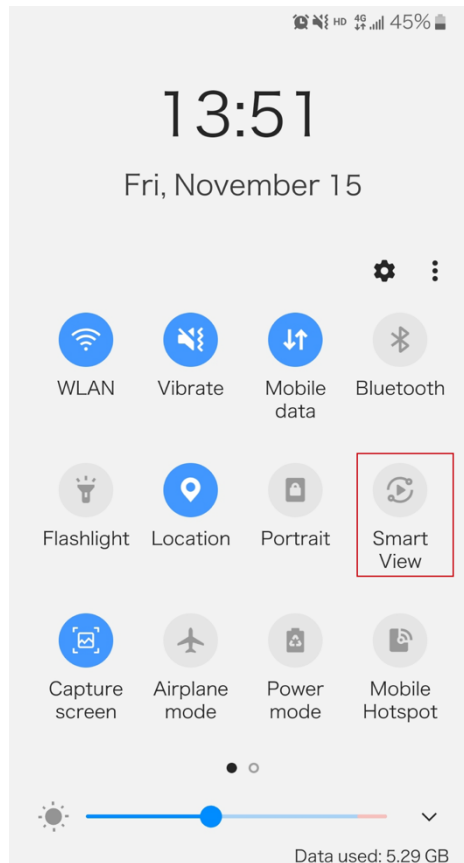

3. The Smart View window appears and starts to search for Miracast receiver. Click the HT-RANGER device name in the search result and the device will output the mobile screen.

3. Screen mirroring over Miracast

For Windows 10 PC:

1. Enable the WLAN feature of your PC.
2. Click the icon on bottom right of the screen to open **Action Center**.

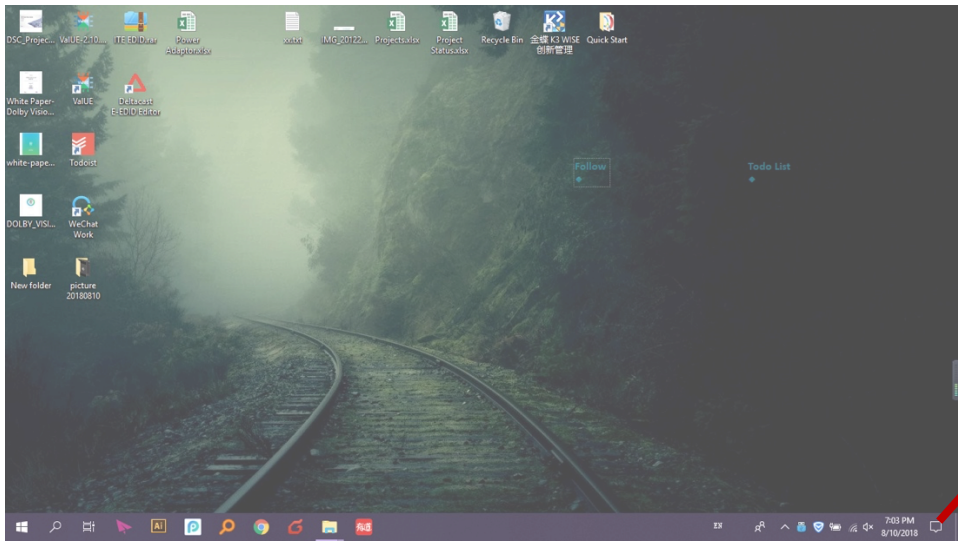

3. Click **Connect**.

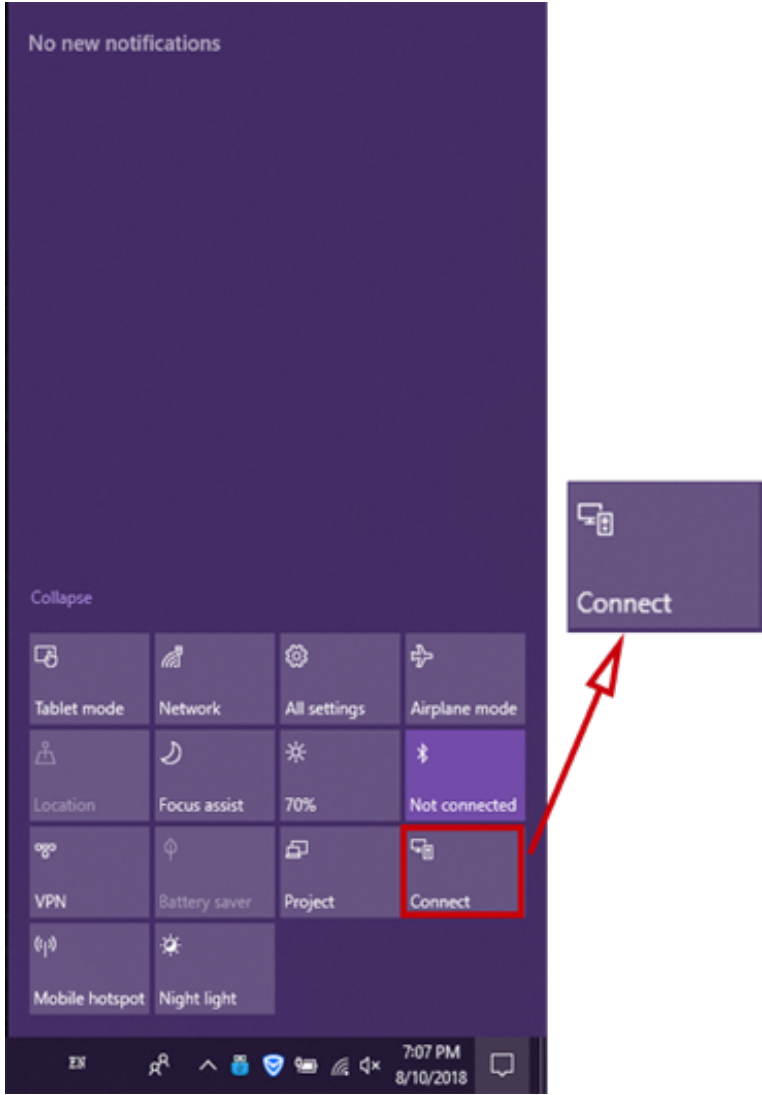

4. Click the HT-RANGER device name in the search results.
5. The HT-RANGER device displays the PC's content once your PC is connected to the device successfully.
6. To disconnect PC from the device: click **Disconnect**.

Note:

- The icon and interface of the Miracast function may vary on different computers.
- Some Windows 10 computers may fail to perform screen mirroring with Miracast due to compatibility issues.

Tip: Both the AirPlay mirroring and Miracast support access code. If you see the PIN entry window appears on your devices, input the access code which can be obtained through OSD. (See "[OSD](#)" section for more information.)

4. Screen mirroring over HT-VOYAGER

HT-VOYAGER allows you to share your laptop's content on the display screen without installing any additional software. Simply plug in the HT-Voyager into USB-C and click the button. For more information, see the user guide of HT-VOYAGER.

Steps to share laptop's screen on the display using HT-Voyager:

1. **Pair the HT-VOYAGER with the switcher.** Connect the HT-VOYAGER to the PAIRING port of the switcher for pairing. Once pairing is completed, "Pairing successful" appears on the display screen. (This will take around 20 seconds to complete.)
2. **Connect the HT-VOYAGER to a laptop.** The HT-VOYAGER will start running when connected into a laptop and will automatically connect to the switcher's soft AP. Once the HT-VOYAGER connects to the switcher successfully, the LED stops blinking and will be solid white.
3. To mirror the laptop, press the HT-VOYAGER's projecting button. To display laptop's screen in full screen, press and hold the button for at least 5 seconds.

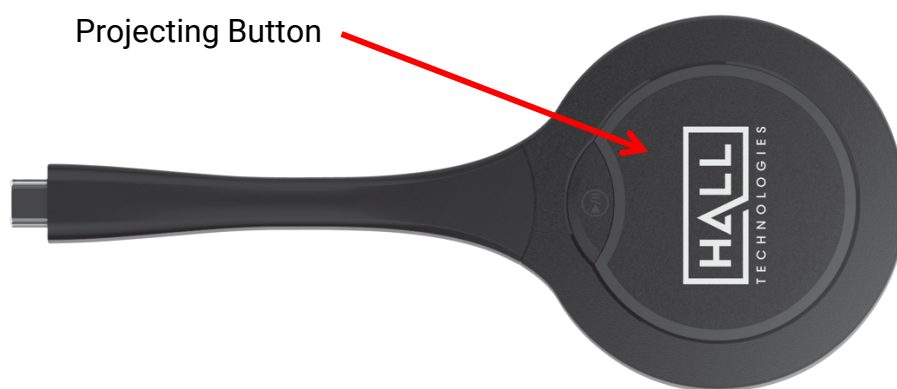

Note: For more information about HT-Voyager, see the HT-Voyager user guide.

DUAL VIEW DISPLAY

By default, the switcher allows up to two video sources to be displayed on a single screen.

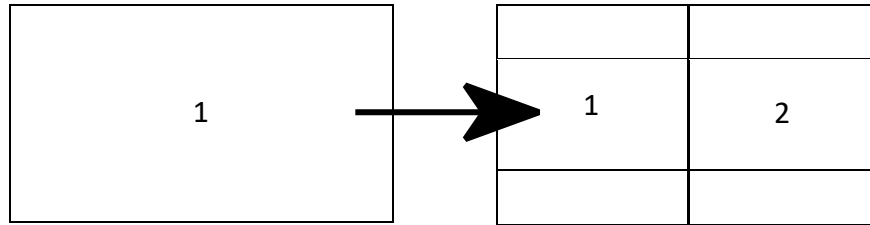

The source combinations and switching sequence for dual view is as follows:

1. Only one hard-wired video source (HDMI or USB-C) can be displayed in dual view
Screen mirroring source + Screen mirroring source: ✓
Screen mirroring source + HDMI In source: ✓
Screen mirroring source + USB-C In source: ✓
HDMI In source + USB-C In source: X
Note: To learn more about screen mirroring source, see [Screen Mirroring](#) section.
2. If two wireless video sources are being displayed in dual view and a third video source is connected the latest connected video input source will replace the source that has been connected longer to the HT-RANGER.
3. If one of the dual video sources is a hard-wired source (HDMI or USB-C) and a second wireless video source is connected, the or the latest connected source will replace the hard-wired video source.

Note: The Dual View Display function can be disabled by API commands. For more information, see the separate HT-RANGER API documentation.

AUTOMATIC SIGNAL SWITCHING

The automatic signal switching function allows for quick and easy video switching without the need for user control. By default, the automatic signal switching function is set as enabled.

1. When there is only one video input source connected, the switcher will automatically output and display it on the screen.
2. When a third video input source is connected and the two video sources are being displayed in dual view, this latest input source will replace either of the sources being displayed. For more information, see the switching mechanism in the [Dual View Display](#) section.
3. If all video sources are removed, the switcher will output the Guide Screen picture.

The switcher also offers the following manual methods to switch to a specific video source:

1. Using web UI.
2. Using API commands. For more information, please see the separate API documentation.

GUIDE SCREEN

The device uses a Guide Screen to convey the basic connection instructions for users. The Guide Screen can be personalized to allow custom connection instructions on the device's Web UI page.

When all video sources are disconnected from the device, the following Guide Screen appears on the display screen automatically:



Note:

- This Guide Screen picture can be changed through the Web UI setting. Please refer to [Guide Screen](#) section for more information.
- By default, if the Guide Screen is being displayed for 60 seconds with no wireless casting connectivity, a countdown timer with the time period of 60 seconds will appear. When the timer ticks to zero, if the connected display is CEC-supported, it will enter standby mode.

The Guide Screen is accessible in the following cases:

- Automatic switching: by disconnecting all video sources from the switcher, the Guide Screen appears automatically.
- Manual switching:
 - ➔ Through Web UI page. For more information, see [State & Switch](#) section.
 - ➔ Send API command through telnet to the switcher to show the Guide Screen. For more information, see the separate HT-RANGER API documentation.

OSD

The switcher supports OSD (On Screen Display) to convey device basic information, including the video source's information, access code, device name, IP address, and Wi-Fi password. The following are two different OSD examples.

Example 1: Full screen mode



Example 2: Dual Display mode

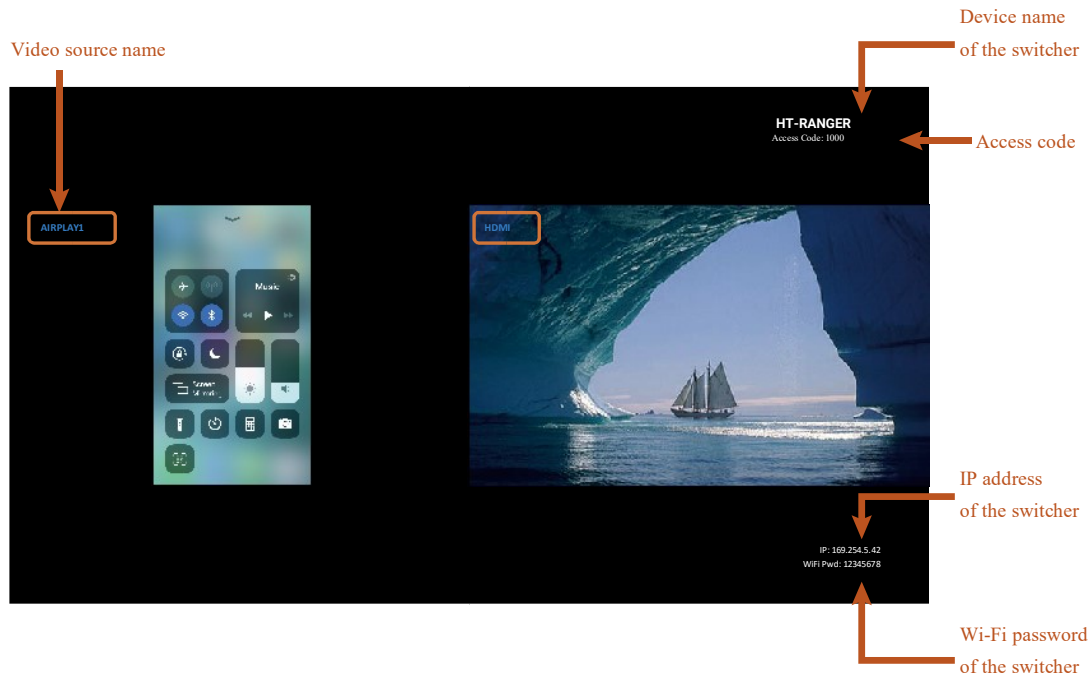

Note:

- When the switcher outputs the Guide Screen, the OSD will be displayed continuously until the countdown timer reaches zero.
- When the device outputs video input sources, the OSD will be displayed for 10 seconds and then will disappear.
- By default, the access code is set as blank, and therefore the OSD doesn't display the access code. If you want to set access code, please see BYOD section for more information.

Web GUI

The Web UI designed for this switcher allows for basic controls and device settings. This Web UI can be accessed through a modern browser, e.g. Chrome, Safari, Firefox, IE10+, etc.

To get access the Web UI:

1. Connect the LAN port of the switcher to a local area network. Ensure there's a DHCP server in the network so that the device can obtain a valid IP address. (If there is no DHCP server the switcher will revert to a 169.254.x.x address which you can find on the OSD. Use this to change the switcher IP to a static IP address and set your own.)
2. Connect the PC to the same network as the switcher.
3. Input the switcher's IP address in the browser and press Enter, the following window pops up. (See [OSD](#) section to easily view the IP address)

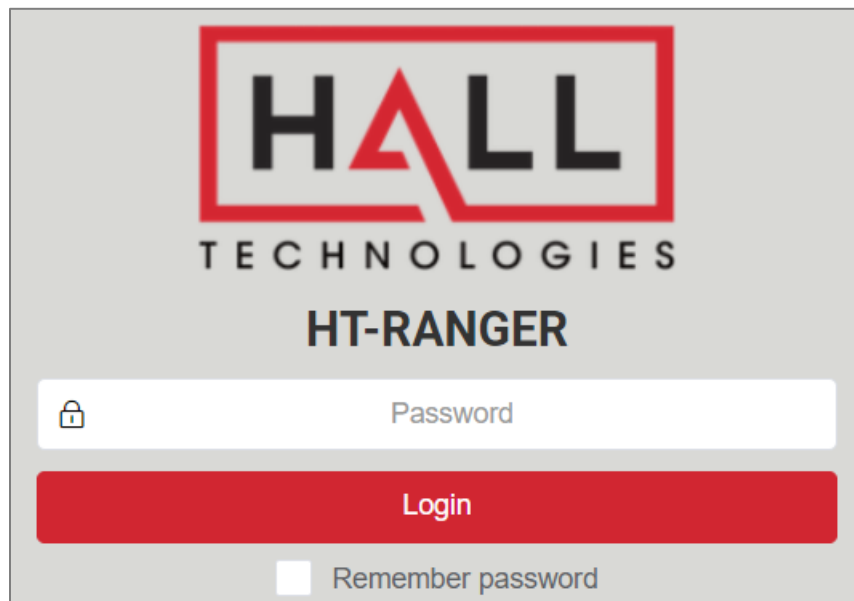

4. Input the password (default password: **admin**) and click **Login** to enter the main page.

General **Video Source**

Device Name	▼
Wired Network	▼
BYOD	▼
Soft AP	▼
Output	▼
Display Control	▼
Wi-Fi Settings	▼
Password	▼
Guide Screen	▼
Maintenance	▼
Version Info	▼

The Web UI main page includes General and Video Source Tabs.

- General – offers settings of network & Wi-Fi, BYOD, Soft AP, Display Control, USB Switching, password, Guide Screen, Maintenance, etc.
- Video Source – offers settings of source switching and alias management.

General Page

DEVICE NAME

Device Name

Device Name

Note: The device name must be 1~20 characters in length(letters numbers '_' or '-').

Apply

UI Element	Description
Device Name	Change the device name if desired. This name also acts as the name of soft AP and the receivers of AirPlay and Miracast. Note: The name must be 1~20 characters in length, including letters, numbers, “_” or “-”. By default, it is set as HT-RANGER .
Apply	Click to apply setting changes.

WIRED NETWORK

Wired Network

IP Mode Static DHCP

IP Address

Netmask

Gateway

DNS Server 1

DNS Server 2

Note: After changing network configuration, please reopen the web page with the new network settings.

Apply

UI Element	Description
Network	Used to modify network settings.
IP Mode	Select the desired IP mode between DHCP and Static. (Default is DHCP)
IP Address	Set the IP address manually if Static mode is selected.
Netmask	Set Subnet Mask manually if Static mode is selected.

Gateway	Set gateway address manually for the device to communicate with another network that uses different communication protocols when Static mode is selected.
DNS Server 1	Set DNS server manually for the switcher to ensure normal network communication.
DNS Server 2	
Apply	Click to apply setting changes. Note: After the IP settings are changed, please refresh the Web UI page to re-login.

BYOD

BYOD ^

BYOD Feature

On
Off

Apply

Access Code

(0000 ~ 9999 or blank) Auto

Refresh
Apply

UI Element	Description
BYOD Feature	<ul style="list-style-type: none"> On: Enable the device's BYOD feature. Off: Disable the device's BYOD feature. <p>Note: This feature is available for AirPlay and Miracast, not for HT-Voyager.</p>
Access Code	<p>Enter a four-digit access code to help prevent users from accidentally connecting to an unintended device and protect from unauthorized access.</p> <ul style="list-style-type: none"> When an access code is configured, it appears on the upper right corner of the display. If you don't want to set access code, you can leave this blank. <p>By default, it is set as blank.</p>
Refresh	Click to refresh to show the latest access code.
Auto	<p>When "Auto" is checked, the device randomly generates a four-digit access code in the following cases:</p> <ul style="list-style-type: none"> The device switches to Guide Screen. The device reboots.
Apply	Click to apply setting changes.

SOFT AP

Soft AP On Off

[Apply](#)

Soft AP Password

Note: The soft ap password must be 8~20 characters in length(letters numbers '_' or '!').

[Apply](#)

Soft AP Router On Off

Note: This feature depends on the soft AP, to use this feature, please make sure the soft AP is enabled.

[Apply](#)

UI Element	Description
Soft AP	Click to enable/disable the switcher's soft AP function.
Soft AP Password	Configure soft AP password. Note: The soft AP password must be 8~20 characters in length, including letters, numbers, "_" or "!".
Soft AP Router	<ul style="list-style-type: none"> Enable: Enable the device's soft AP router function so that wireless devices connected to soft AP can access the internet (in the condition that the LAN port of the device is connected to the internet). Disable: Disable the device's soft AP function to prevent wireless devices connected to soft AP from accessing the internet. <p>Note:</p> <ol style="list-style-type: none"> (1) Before you use this feature, ensure the soft AP function is enabled. (2) When the device's IP mode is set as Static, you must configure the LAN port's gateway and DNS correctly so that soft AP router runs properly.
Apply	Click to perform current settings.

OUTPUT

Output
⌵

Output timing

3840x2160P@30 v

Auto

Refresh
Apply

Output HDCP Support

On

Off

Apply

Auto StandBy (Minute, ranges from 0 to 60, set to 0 for deactivation)

1

Apply

UI Element	Description
Output timing	<p>Set the output resolution for HDMI Out. Two operation methods are offered.</p> <ul style="list-style-type: none"> Auto: select to output the maximum resolution supported by display based on the display's EDID. E.g. If display supports up to 4K@60Hz, the device outputs 4K@60Hz. Resolution range list: select a desired output resolution from the drop-down menu to output this fixed resolution. <p>By default, it's set as Auto.</p>
Output HDCP Support	<p>Set the HDCP capability for HDMI Out and HDBT Out.</p> <ul style="list-style-type: none"> Follow: Set the output HDCP of HDMI Out to follow the HDCP capability of the video input. HDCP 1.4: Set the output HDCP of HDMI Out to HDCP 1.4. <p>By default it is set as Follow.</p>
Auto Standby (Minute, ranges from 0 to 60, set to 0 for deactivation)	<p>Set a period of time that remains before the countdown timer begins for auto standby.</p> <ul style="list-style-type: none"> For example, when the current input is Guide Screen, 1 minute means if there's no signal present at the device in 1 minute, the countdown timer for device standby begins; when the timer ticks to zero, the device enters standby mode. Note: If the connected display doesn't support CEC or isn't correctly set with RS232 commands, the word "Standby" appears in the middle of the Guide Screen. If it's set to 0 minute, it means this function is disabled and you cannot set the device to standby mode. <p>By default, auto standby is set as 1 minute.</p>
Refresh	Click to refresh to the latest status of the output timing.
Apply	Click to apply setting changes.

DISPLAY CONTROL

Display Control
^

Use CEC to control display	<input checked="" type="checkbox"/> On <input type="checkbox"/> Off
Interval between two consecutive commands to the sink(Second, ranges from 0 to 200)	<input style="width: 100%;" type="text" value="8"/>
Stop Video Signal In Standby Mode	<input type="checkbox"/> On <input checked="" type="checkbox"/> Off

UI Element	Description
Use CEC to control display	Click to enable/disable CEC control on display. Default setting: Enable
Interval between two consecutive commands to the sink (Second, ranges from 0 to 200)	Specify a time interval between sending two consecutive commands to the sync (in seconds). The interval should not be less than 0s. Note: Check with the display manufacturer for info on recommended CEC command intervals. By default, the interval is set as 8 seconds.
Stop Video Signal In Standby Mode	<ul style="list-style-type: none"> Enable: Click to stop transmitting the video signal to the display when the device is in standby mode. Disable: Click to continue transmitting the video signal to the display when the device is in standby mode. Default setting: Disable
Power On	Click to power on the connected display.
Power Off	Click to power off the connected display.
Apply	Click to apply setting changes.

WI-FI SETTINGS

Wi-Fi Settings ^

Band	<input type="radio"/> 2.4G <input checked="" type="radio"/> 5G
Channel	<input type="text" value="40"/> <input type="checkbox"/> Auto

Apply

UI Element	Description
Band	<ul style="list-style-type: none"> 5G: Configure the device's frequency band as 5GHz. 2.4G: Configure the device's frequency band as 2.4GHz. <p>By default, the device works at 5GHz. If your wireless devices don't support 5GHz, configures the frequency band as 2.4G before connecting them to the device via Miracast.</p>
Channel	By default, the Channel is set to Auto. If a different wireless channel is desired, uncheck Auto and select the desired channel.
Apply	Click to apply setting changes.

PASSWORD

Password ^

Old Password	<input type="text"/>
New Password	<input type="text"/>
Confirm new password	<input type="text"/>

Note: Password must be 4 to 16 characters in length, alphanumeric only.

Apply

UI Element	Description
New Password	Set a new login password.
Confirm Password	Note: The new password must be 4 to 16 characters in length, alphanumeric only.
Apply	Click to apply setting changes.

GUIDE SCREEN

Guide Screen ^

File: **Browse**

Apply

Note: You must upload an image in jp(e)g format that has 1920 x 1080 pixels.

UI Element	Description
Browse	Set a new picture for the Guide Screen.
Apply	Click to upload the picture file to the device. Note: The picture must be in jpeg format that has 1920 x 1080 pixels.

MAINTENANCE

Maintenance ^

Upgrade

File: **Browse**

Apply

Note: The legal firmware package is a .zip archive. The system will be rebooted to finish upgrading.

Reboot
Reset To Factory Default
Export Log

UI Element	Description
Browse	Click to browse for the local upgrade file for firmware upgrade.
Apply	Click to apply the upgrade file to the device. Note: The upgrade file is a .zip archive. After the upgrade file is uploaded completely, the device reboots.
Reboot	Click to restart the switcher.
Reset to Factory Default	Click to restore the switcher to its factory defaults. You can also perform this task by using the Reset button on front panel.
Export Log	Click to export log (.tar.gz) to a local computer.

VERSION INFO

Version Info	
Version	V1.3.1
Build Time	2022.12.17 14:27:00

UI Element	Description
Version	Displays the switcher's firmware version.
Build Time	Shows the time and date when the switcher's firmware was built.

Video Source Tab

STATE & SWITCH

State & Switch				
Primary	Video Source	Timing	Format	Addition
<input type="radio"/>	USB-C	NoSignal		
<input type="radio"/>	HDMI	NoSignal		
<input checked="" type="radio"/> Show Guide Screen				<input type="button" value="Refresh"/>

UI Element	Description
State & Switch	Displays the video signal status (including video source channel, video resolution and video format).
Primary	Click the button (turns from white to red) to output the video source(s).
Show Guide Screen	Click the button (turns from white to red) to output the Guide Screen.
Refresh	Click to refresh the current state information.

MANAGE ALIAS

Manage Alias ^

Video Source	Alias
USB-C	
HDMI	

Apply

UI Element	Description
Video Source	Displays the video source name.
Alias	Enter a name to change the video source name to a new one. Note: The name should be within the length of 1~20 characters including letters, numbers, underscores “_” and hyphens “-”. If you don’t want to change the name, leave it blank here.
Apply	Click to apply setting changes.

SWITCHING POLICY

Switching Policy ^

Multiview Feature On Off

Apply

Fall-back Policy Normal v

Apply

UI Element	Description
Multiview Feature	<ul style="list-style-type: none"> On: allows two sources to be displayed side-by-side. These sources can be any combination of USB-C, HDMI, and two wireless casting devices and are selected in video switching. Off: displays one source at a time full screen.
Fall-back Policy	<ul style="list-style-type: none"> Normal: reverts back to the last selected source. HDMI: reverts back to the HDMI input when a source in USB-C or wireless casting is disconnected. USBC: reverts back to the USB-C input when a source in HDMI or wireless casting is disconnected.
Apply	Click to apply setting changes.

Firmware Upgrade

The switcher supports a firmware upgrade using the Web UI and through the USB-A port on rear panel. To upgrade the firmware through the Web UI, see [Firmware](#) section.

To upgrade the firmware through the USB-A port on rear panel, perform the following:

1. Name the upgrade file package “HT-RANGER-update.zip”.
2. Create a new folder named “upgrade” under the root directory of a FAT32 or NTFS USB Drive. Place the upgrade file in this folder.
3. Connect the USB Drive to either of the switcher’s USB-A ports. It will take about 1 minute for the switcher to read the USB Drive. If the switcher detects the upgrade file is a newer version, it will start to upgrade automatically. When the upgrade process is complete, the switcher will reboot.

Note:

- Before connecting USB Drive to the switcher, we recommend that you remove the USB-C source from the switcher’s USB-C port.
- Do not disconnect power to the HT-RANGER during the upgrade process.
- If the switcher detects the upgrade file is not a newer version, it will not start the upgrade.

Troubleshooting

Problem Type	Problem	Options
Video	No Video on Display	<p>Confirm the HDMI input on the display is correctly selected</p> <p>Confirm the connected source is sending video to the HT-RANGER (verify the connected laptop is in duplicate or extend mode)</p>
	Choppy video using AirPlay	Make sure the AirPlay device's WiFi is connected to HT-RANGER's soft AP (may need to turn on in Web UI)
USB	USB-C not connecting	<p>Verify connected cable supports USB-C</p> <p>The response time to output video of USB 3.0 and Type-C is typically 6-8 seconds, although the response time between PC's can differ</p> <p>Confirm the PC can transmit video over USB-C by installing the DisplayLink device driver: https://www.displaylink.com/downloads</p>
	PC charge reminder pop-up	<p>This pop-up is normal since the HT-RANGER charging power might be different than what the laptop requires</p> <p>To ensure the laptop doesn't lose power, connect a dedicated power supply</p>
Audio	No audio at far end on soft codec call (i.e. Meet, Teams, Zoom, etc.)	Verify the HT-RANGER microphone is not muted (red LED means muted)
		Verify the microphone selected in the soft codec is the HT-RANGER
		Verify the soft codec microphone is not muted
	No audio heard on the display	Verify the HT-RANGER is selected as the desired speaker output in the laptop by clicking on the speaker icon to open the audio output
Verify the display is not muted		
Verify the levels are turned up on both the laptop and the HT-RANGER		

Specifications

Video	
Input Video Port	1 x USB In; 1 x HDMI In; 1 x LAN; 1 x WLAN
Input Video Signal	<ul style="list-style-type: none"> HDMI: HDMI 1.4, HDCP 1.4 USB-C: DisplayPort 1.1, HDCP 1.4 LAN/WLAN: H.264
Input Resolution	<p>HDMI: 640x480⁸, 800x600⁸, 1024x768⁸, 1280x768⁸, 1280x800⁸, 1280x1024⁸, 1360x768⁸, 1366x768⁸, 1440x900⁸, 1400x1050⁸, 1600x1200⁸, 1680x1050⁸, 1920x1200⁸, 720x480⁸ (480p), 720x576⁶ (576p), 1280x720⁵ (720p30), 1280x720⁶ (720p50), 1280x720⁸ (720p60), 1920x1080² (1080p24), 1920x1080³ (1080p25), 1920x1080⁵ (1080p30), 1920x1080⁶ (1080p50), 1920x1080⁸ (1080p60), 3840x2160⁵(2160p30)</p> <p>LAN/WLAN: Up to 1920x1080⁵ (1080p30) Note: The input resolution support for LAN or WLAN may vary according to the specific BYOD protocols and devices.</p> <p>1 = at 23.98 Hz, 2 = at 24 Hz, 3 = at 25 Hz, 4 = at 29.97 Hz, 5 = at 30 Hz, 6 = at 50 Hz, 7 = at 59.94 Hz, 8 = 60 Hz</p>
Output Video Port	1 x HDMI
Output Video Signal	HDMI 1.4, HDCP 1.4
Output Resolutions	<p>720x480⁸ (480p60), 720x576⁶ (576p60), 640x480⁸, 800x600⁸, 1024x768⁸, 1280x1024⁸, 1366x768⁸, 1440x900⁸, 1280x800⁸, 1680x1050⁸, 1920x2160⁵, 1600x1200⁸, 1920x1200⁸, 2560x1440⁵, 2560x1440⁸, 1280x720⁶ (720p50), 1280x720⁸ (720p60), 1920x1080⁶ (1080i50), 1920x1080⁸ (1080i60), 1920x1080² (1080p24), 1920x1080³ (1080p25), 1920x1080⁵ (1080p30), 1920x1080⁶ (1080p50), 1920x1080⁸ (1080p60), 3840x2160³ (2160p25), 3840x2160⁵ (2160p30)</p> <p>1 = at 23.98 Hz, 2 = at 24 Hz, 3 = at 25 Hz, 4 = at 29.97 Hz, 5 = at 30 Hz, 6 = at 50 Hz, 7 = at 59.94 Hz, 8 = 60 Hz</p>

Audio	
Input Audio Port	1 x HDMI; 1 x USB-C In; 1 x LAN; 1 x WLAN
Input Audio Signal	RAW PCM 2.0, 16 bit, 32/44.1/48KHz sps
Output Audio Port	1 x HDMI
Output Audio Signal	RAW PCM 2.0, 16 bit, 32/44.1/48KHz

Wi-Fi	
Standard	IEEE 802.11 a/b/g/n/ac
Frequency	Dual bands, 2.4~2.4835GHz, 5.0~5.8GH
Throughput	2T x 2R, up to 433Mbps
Security	WEP, TKIP, AES, WPA, WPA2

Control	
Control Connector	1 x RJ45, 10/100/1000Mbps Ethernet
Control Method	LAN (Web UI & Telnet API)

General	
Operating Temperature	0 to + 45°C (32 to + 113°F)
Storage Temperature	-20 to +70°C (-4 to + 158°F)
Humidity	10% to 90%, non-condensing
ESD Protection	Human-body Model: ±8kV (Air-gap discharge)/ ±4kV (Contact discharge)
Power Supply	12V 2A DC
Power Consumption	12W (Max)
Device Dimension (W x H x D)	215mm x 25mm x 120.2mm 8.46" x 0.98" x 4.73" (Antennas not included)
Net Weight	0.68kg/1.5lbs



© Copyright 2022. Hall Technologies
All rights reserved.

1234 Lakeshore Drive Suite #150, Coppell, TX 75019
halltechav.com / support@halltechav.com
(714)641-6607